

MIT
HAYSTACK
OBSERVATORY

Phase Cal Basics

Ganesh Rajagopalan
MIT Haystack Observatory
ganesh@haystack.mit.edu

Pre-recorded Presentation for the virtual
11th IVS Technical Operations Workshop, May 3-5, 2021
*(Acknowledge generous reuse of slides from previous TOW lectures by
Brian Corey)*

Science Objectives: Geodetic VLBI

- Unique contribution to the Celestial Reference Frame (ICRF) and measurement of Earth's Orientation in Space
- Important input to the Terrestrial Reference Frame (ITRF) - scale
- Needed for precise orbit determination, spacecraft navigation, solar system exploration, astrophysics, sea level change, Earth mass exchanges, nutation

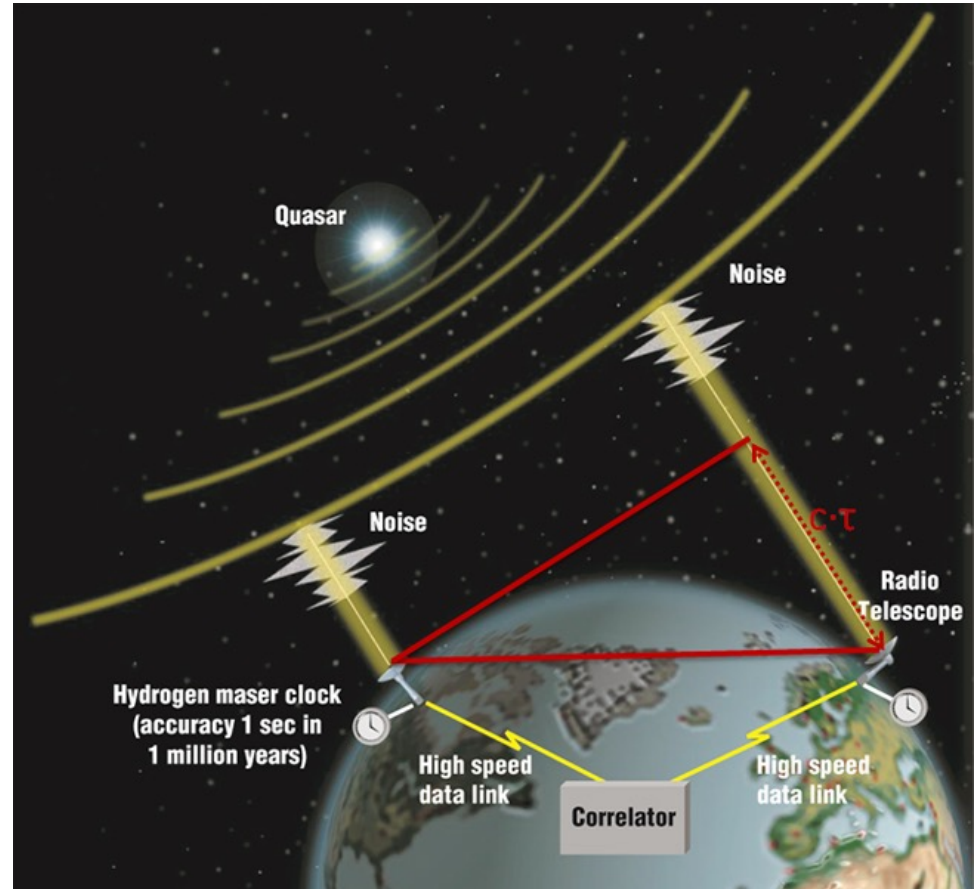

VGOS accuracy goal is 1 mm for site position and 0.1 mm/yr site velocity

Phase/delay calibration systems in VLBI

- Astrometric and geodetic VLBI rely on accurate measurement of phase and delay, devoid of errors caused by instrumentation.
- In absence of perfectly stable systems, calibration signals can be used to measure, and hence correct for, instrumental time and frequency variations of phase and delay.

group delay = slope of phase vs. frequency

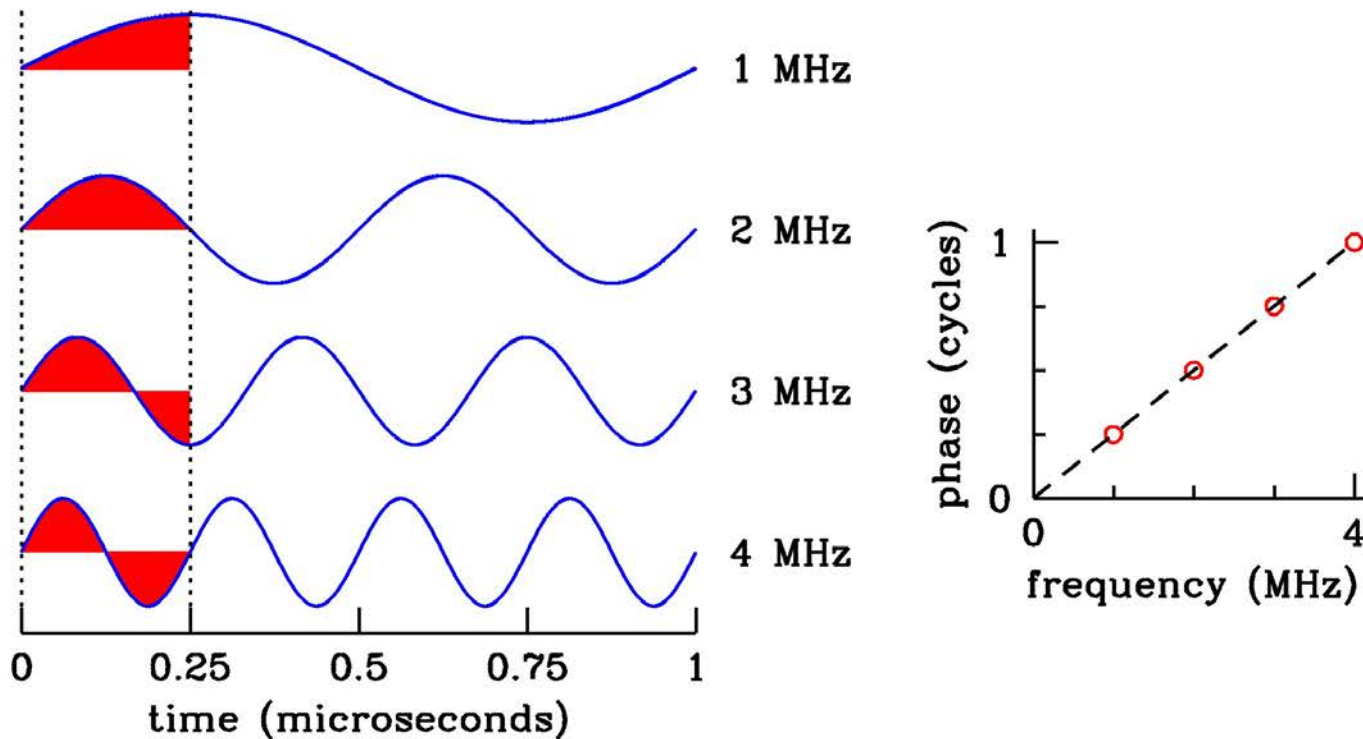

Phase cal signal in time domain, as sum of sinusoids

Say we want a calibration signal every 1 MHz, up to 10 GHz:

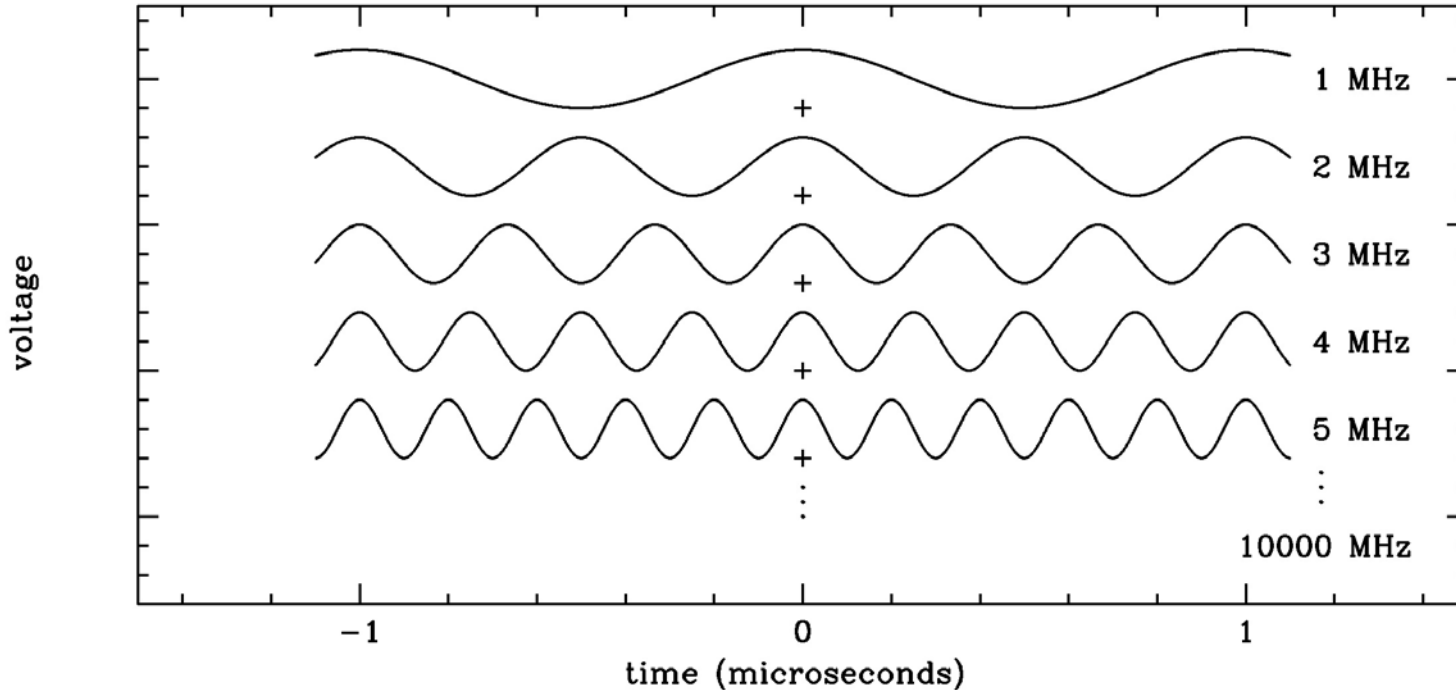

Add up all 10 000 tones and you get...

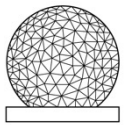

Phase cal in time domain, as pulses

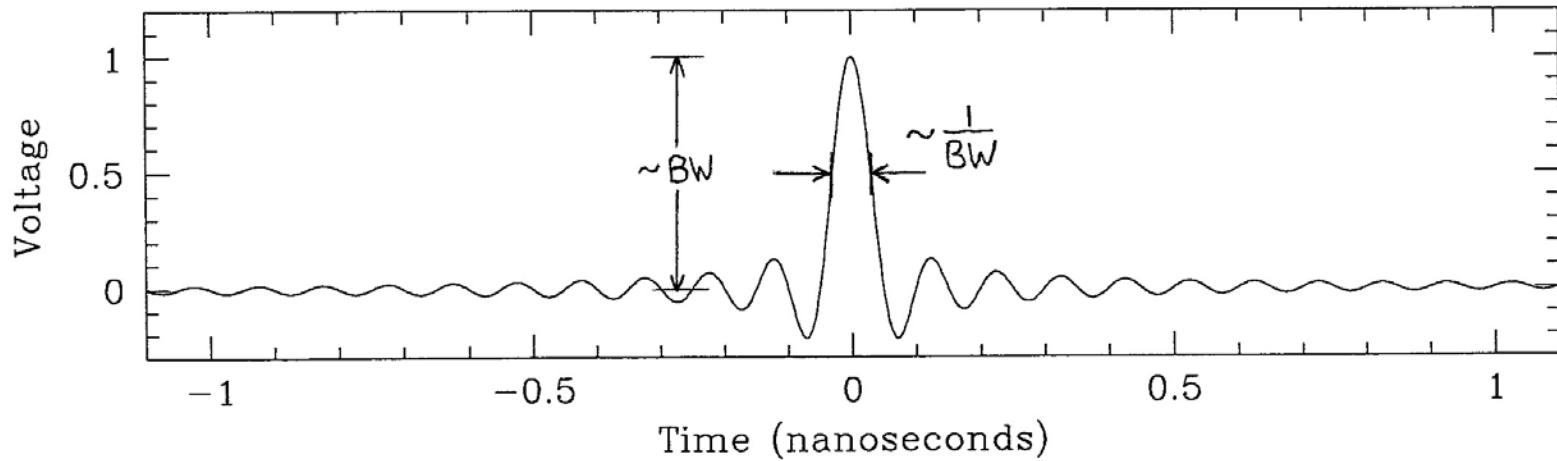
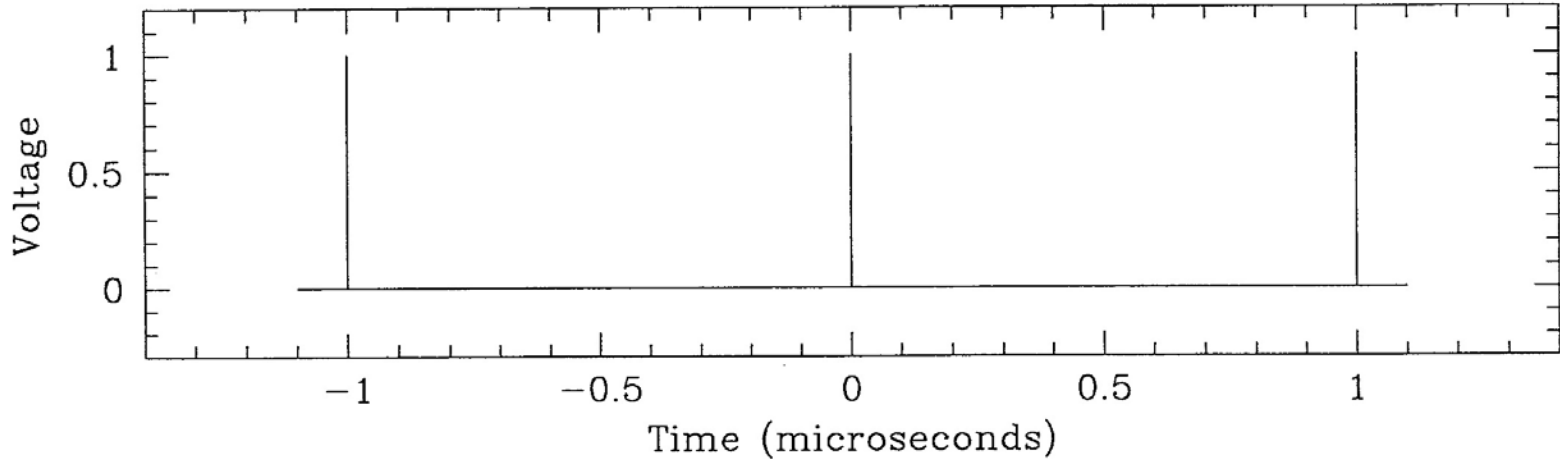

Phase calibration in VGOS

- Primary function remains as always: Measure instrumental phase variations over time and frequency.
- Phase differences between channels are far more stable in VGOS than in S/X VLBI, thanks to digital IF-to-baseband conversion in FPGAs.
- But digital back-ends have not made phase cal obsolete!
 - Phase cal needed in VGOS to measure
 - LO phase drifts between bands
 - Phase/delay drifts in RF/IF analog electronics and cables/fibers
- Increase pulse repetition rate from 1 to 5 or 10 MHz (and pcal tone spacing from 1 to 5 or 10 MHz), to reduce danger of saturation.
 - Because baseband channels are wider (~32 MHz) than in S/X, each channel will still include many pcal tones.
- Options for pcal injection point:

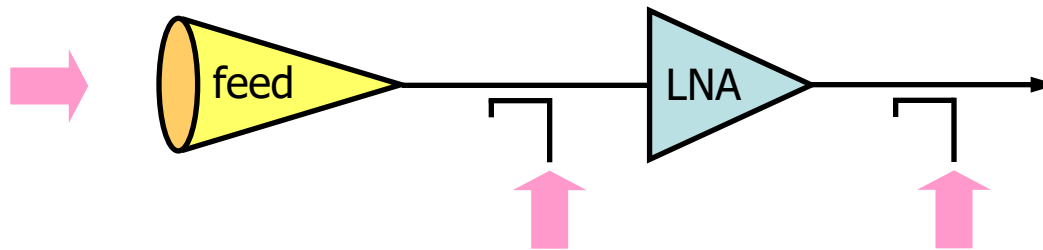

Pulse repetition rate and headroom

- As RF bandwidth increases, pulse intensifies.
 - For 1-MHz pulse rep rate & 1-GHz BW, peak pulse voltage $\sim 10\times$ rms noise.
 - For VGOS RF BW of 12 GHz, peak pulse voltage $\gg 10\times$ rms noise.
- With insufficient analog headroom, pulse drives electronics into nonlinear operation. \rightarrow spurious signals generated that corrupt undistorted pcal signal
- Options to avoid driving electronics into saturation:
 - Reduce pulse strength
 - Phase cal SNR reduced \rightarrow noisier phase extraction
 - More prone to contamination by spurious signals
 - Reduce pulse strength *and* increase pulse repetition rate to 5 or 10 MHz
 - Fewer tones spaced 5 or 10 MHz apart
- With 5 or 10 MHz rep rate, baseband tone frequencies can differ from channel to channel when channel separation = 2^N MHz.
 - Fringe-fitting is more complicated if only one tone per channel is extracted.
 - Software solution: Use multiple tones per channel and correct for delay within each channel, as well as between channels.
- General recommendation: peak pcal pulse power / P1dB < -10 dB

Effects on phase cal of changing bandwidth or pulse rate

Pulse voltage scales with frequency bandwidth -

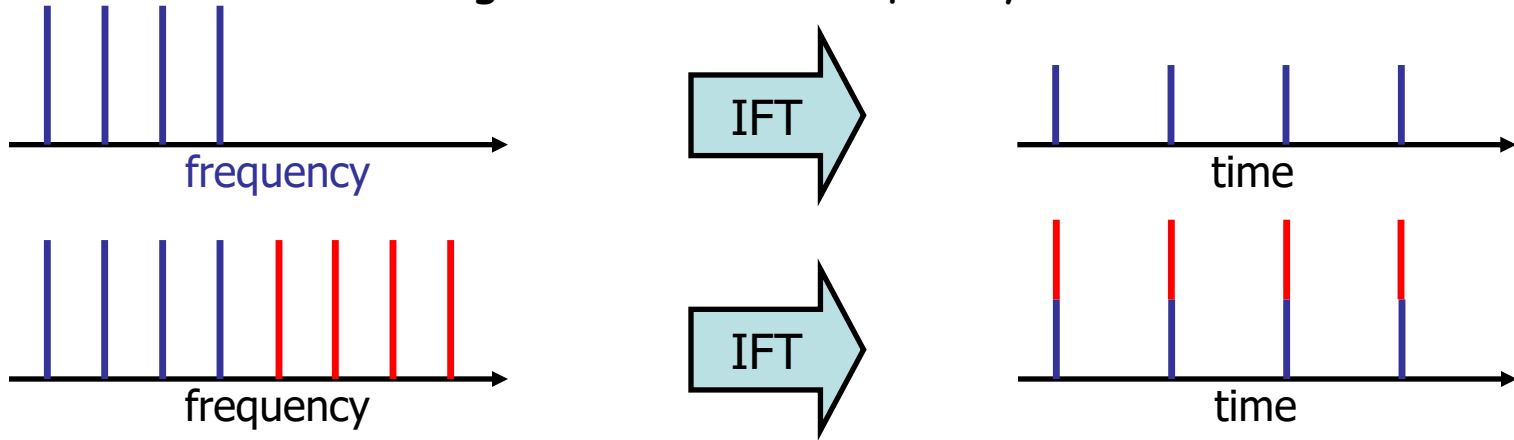

Amplitude and spacing of frequency tones scales with pulse rate -

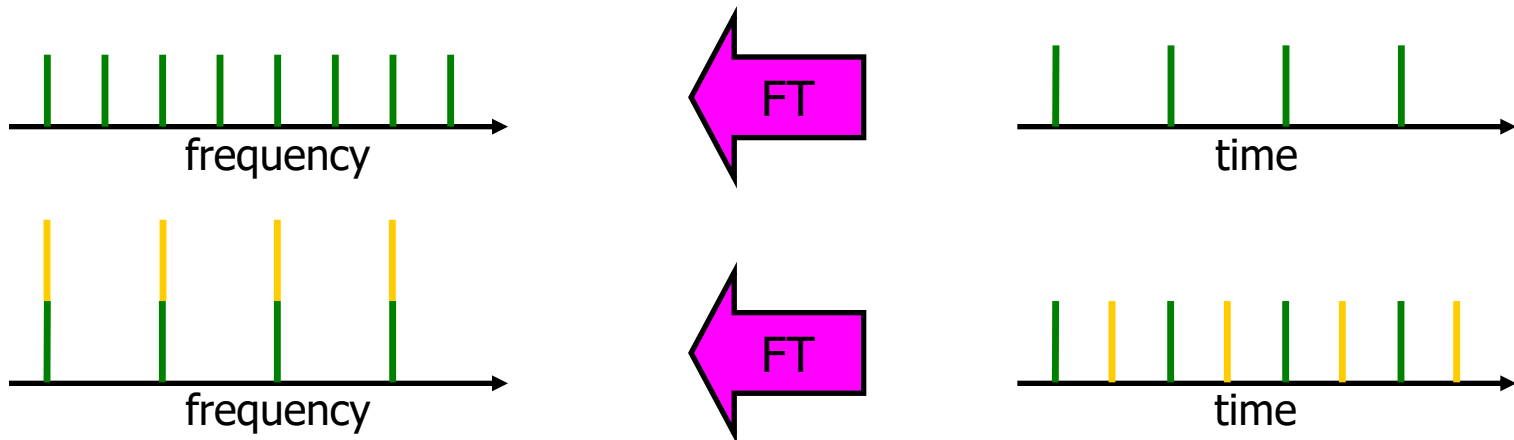

Using multiple phase cal tones in each frequency channel

- With one phase cal tone per channel, only a phase offset can be estimated.
- But a simple phase offset may be inadequate if
 - instrumental phase varies rapidly over frequency, or
 - baseband tone frequency varies from channel to channel.
- Solution: Measure phase of multiple tones in each channel and solve for the frequency dependence of the phase.
- Advantages: Higher SNR and improved phase VLBI phase/delay stability.

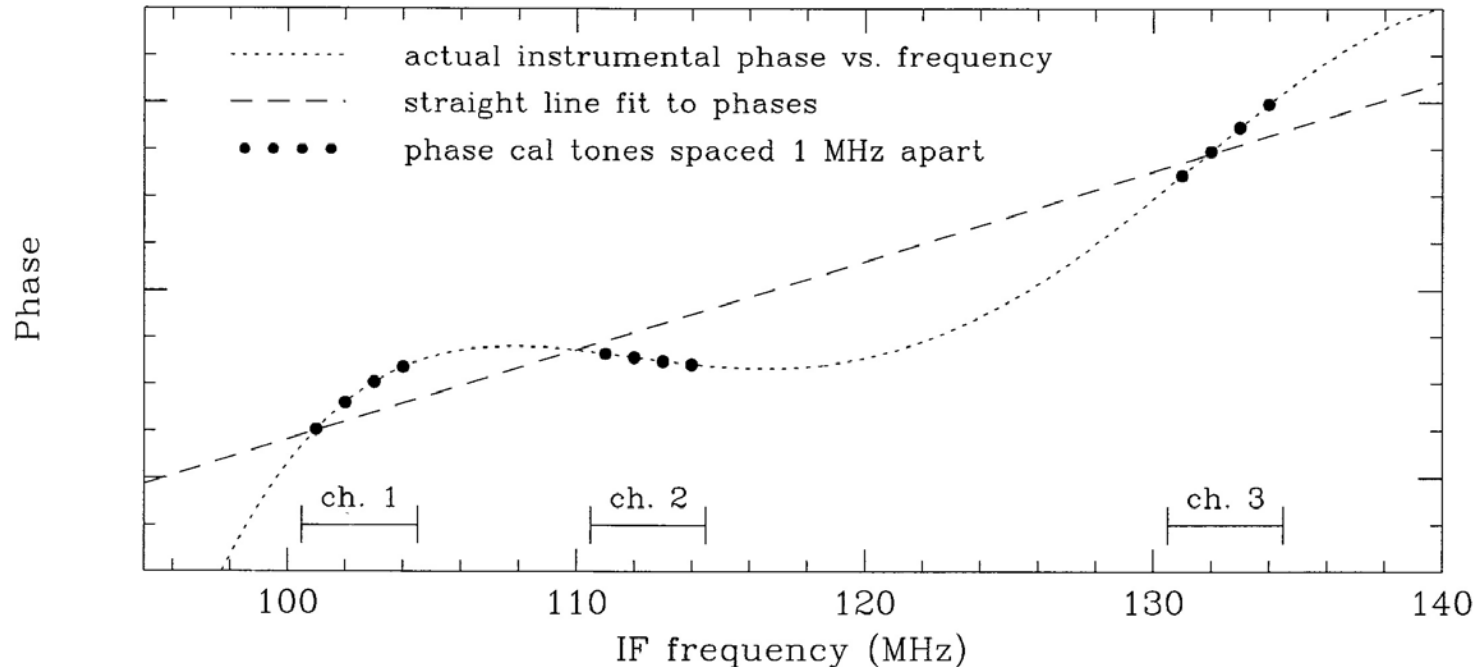

Haystack "digital" phase calibrator

- Tunnel diodes at heart of many older pulse generators are no longer available.
- High speeds of today's logic devices allow a generator to be built around them.
- "Digital" phase calibrator designed by Alan Rogers (Haystack).
- 5 or 10 MHz sinewave input; output pulse train at same frequency.
- Output spectrum flatter than in older tunnel diode design in legacy S/X.
- Pulse delay temperature sensitivity $< 1 \text{ ps}/^\circ\text{C}$ with no external temp. control.
- Support for cable measurement system.
- Circuit diagram and details available at http://www.haystack.mit.edu/geo/vlbi_td/BBDev/023.pdf.

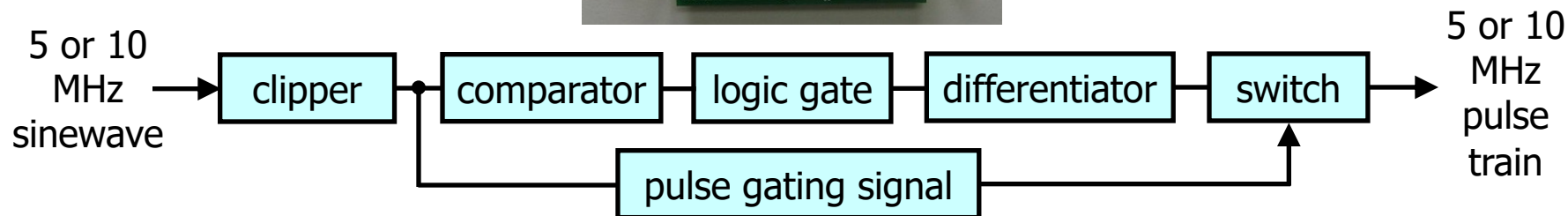
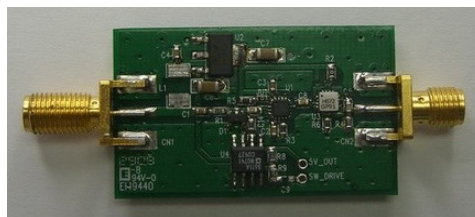

- "Cal box" developed by Haystack Observatory for VGOS front-ends
- Cal box includes
 - digital phase calibrator
 - noise source
 - 0-31.5 dB programmable attenuators on phase and noise outputs
 - noise and phase cal gating
 - RF-tight enclosure
 - Peltier temperature controller ($\Delta T < 0.2^{\circ}\text{C}$ for 20°C change in ambient T)
 - monitoring of temperature, 5 MHz input level, attenuation, gating
- Two identical RF outputs with combined pcal+noise
- Equalizers for phase or noise cal signals can be added if necessary.

Broadband phase/noise cal box: RF connections

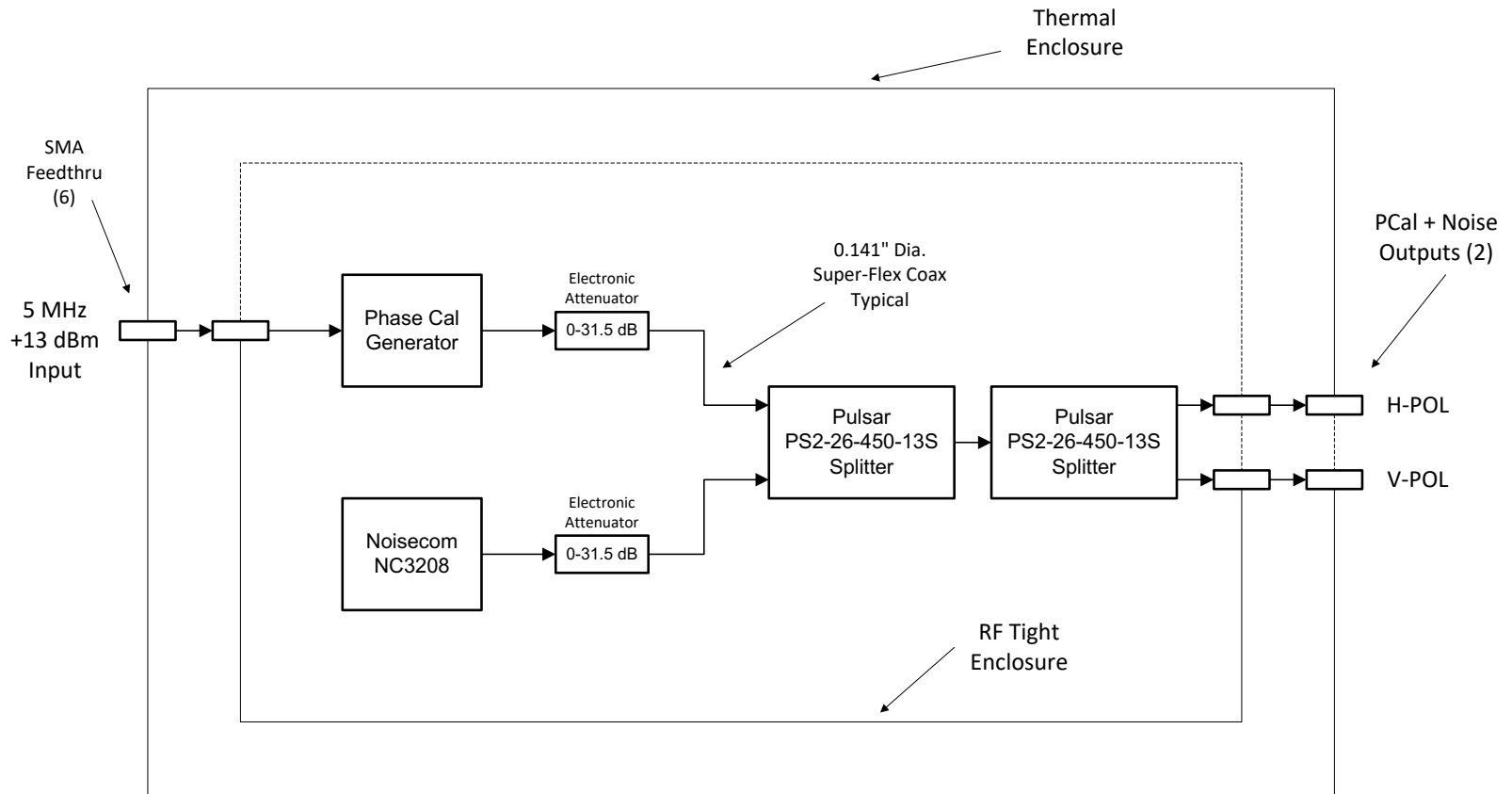

Broadband Phase/Noise Calibration Unit RF Wiring Diagram

VGOS Signal Chains in the NASA network in the USA

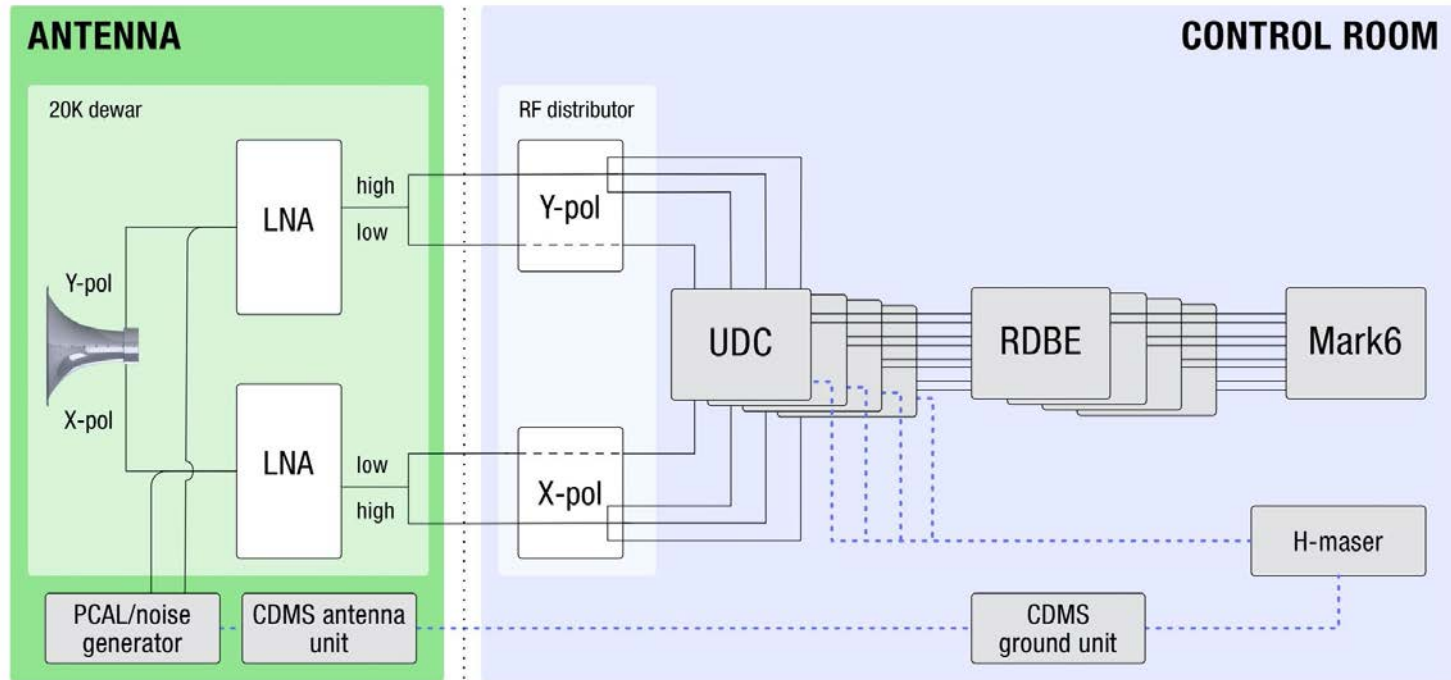
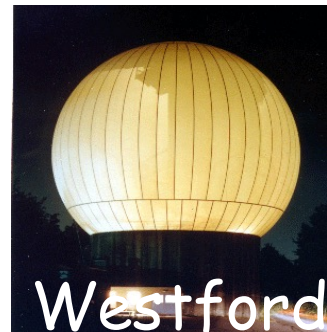

- VGOS observations use four 0.5 GHz or 1 GHz bands in the 2.2-14 GHz range
- Frequency Agile Up-Down Converter (UDC) enables tuning to different frequencies within the 2.2 to 14 GHz frequency range

Cable Delay Measurement System (CDMS) Block Diagram

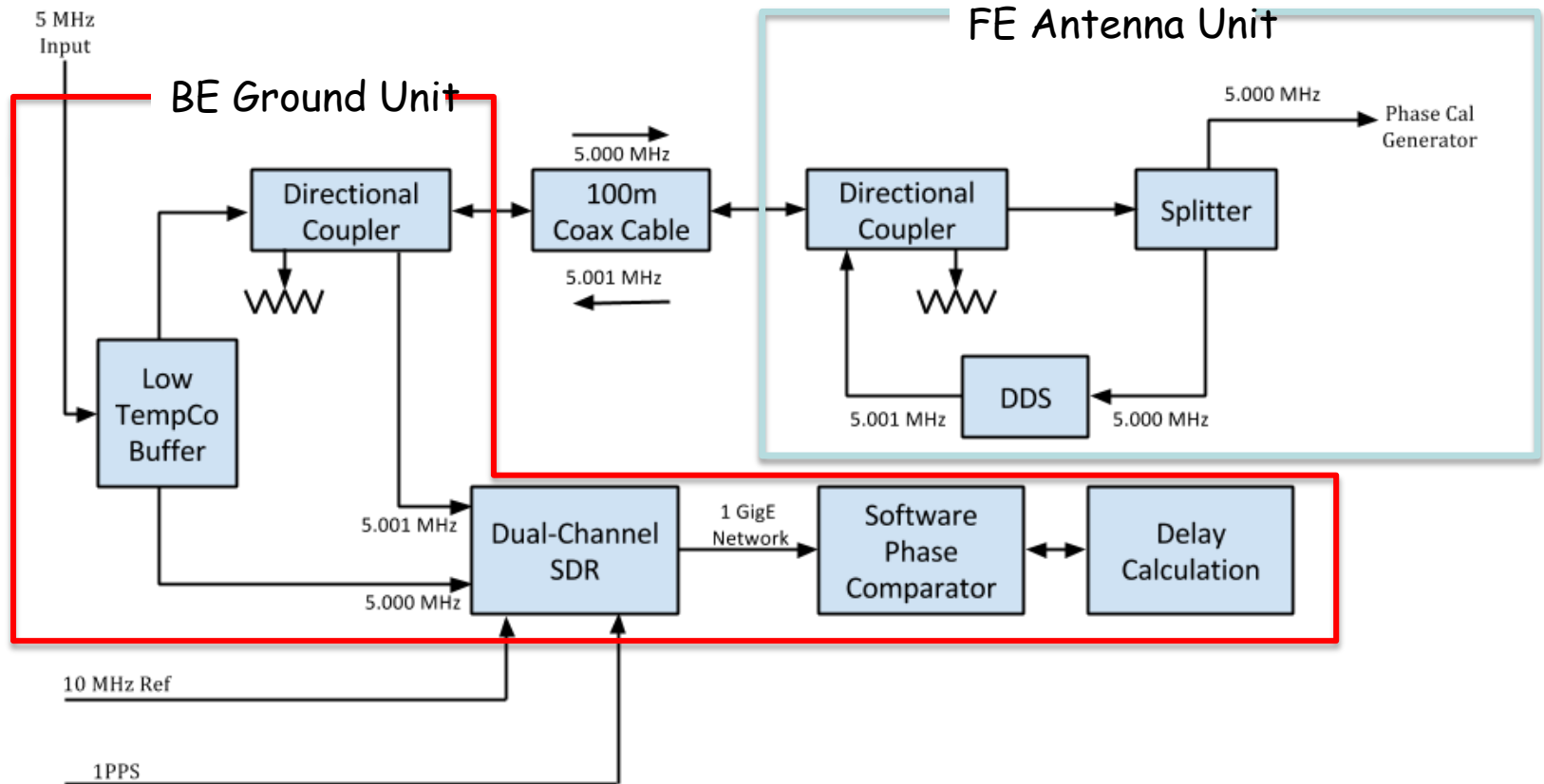

Calibration - Antenna Unit

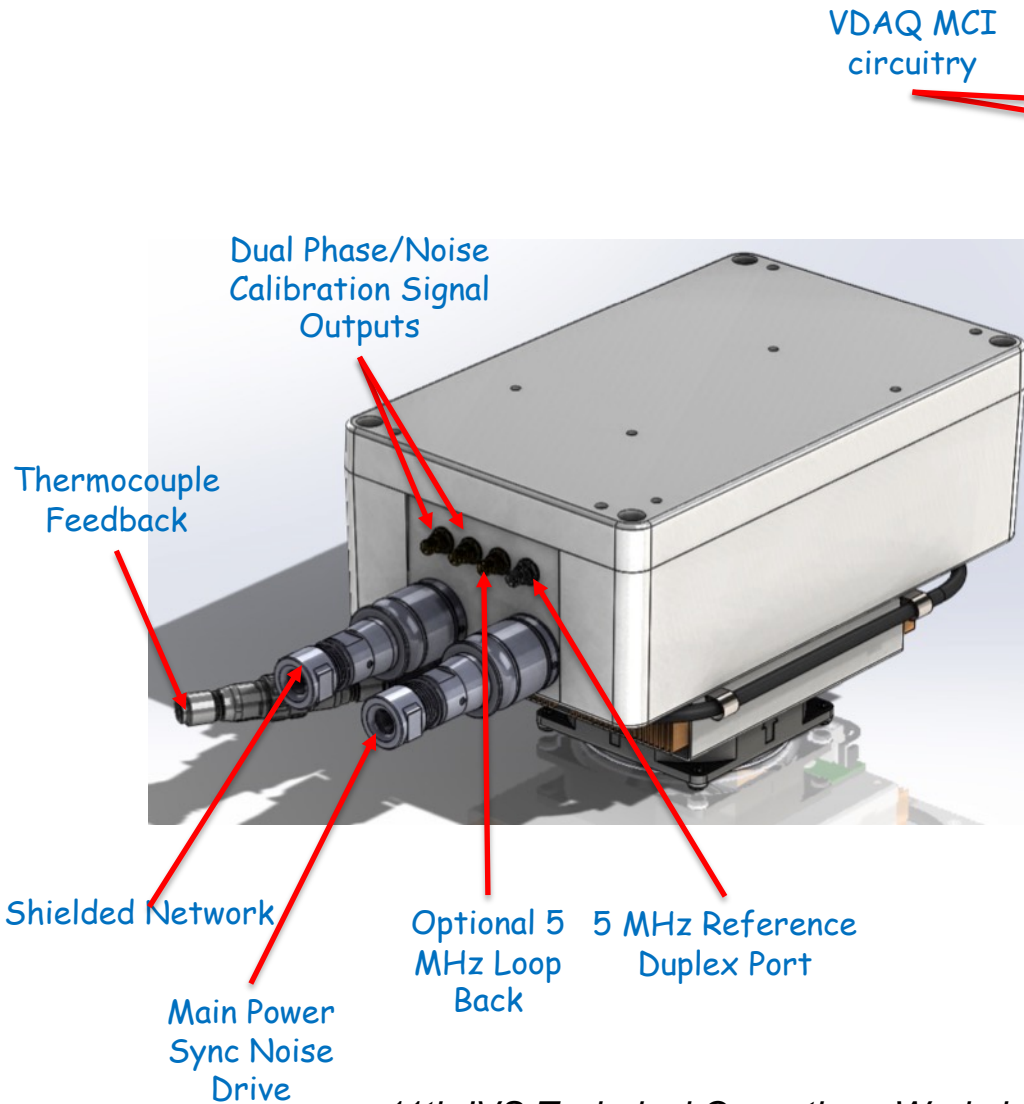

VDAQ MCI circuitry

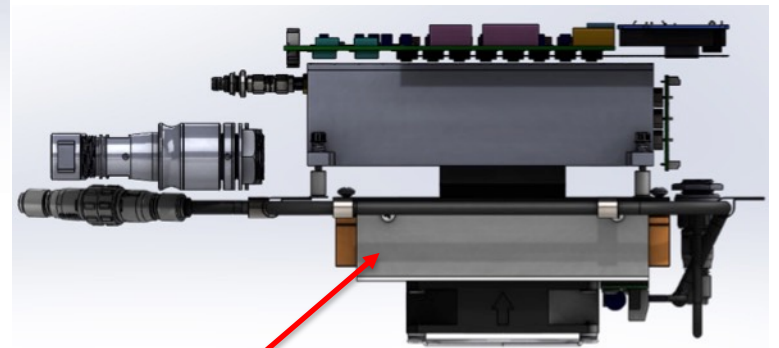
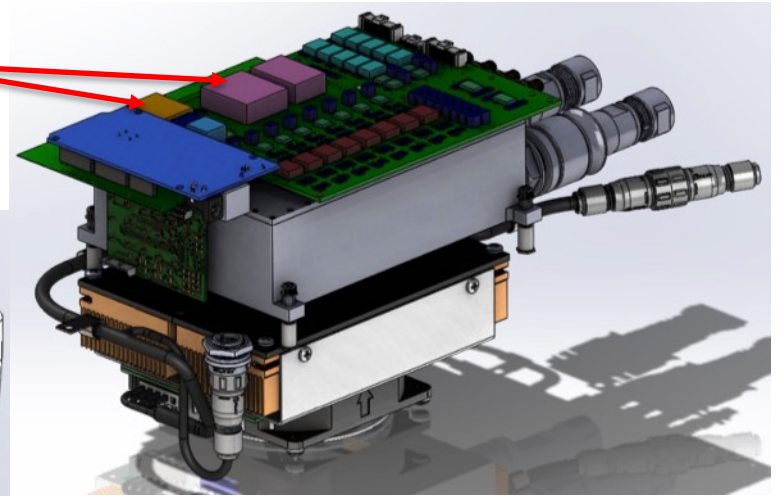

TE Heater

Calibration - Antenna Unit

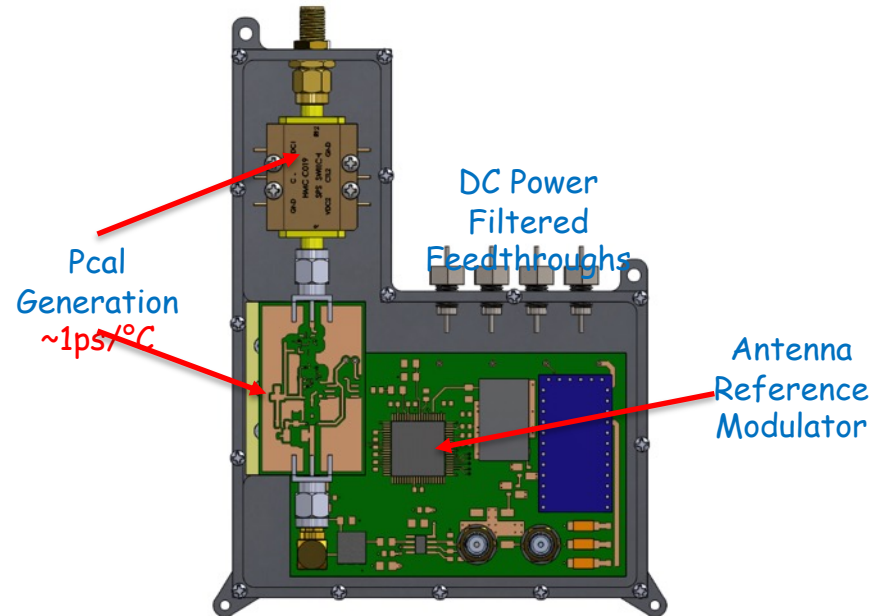
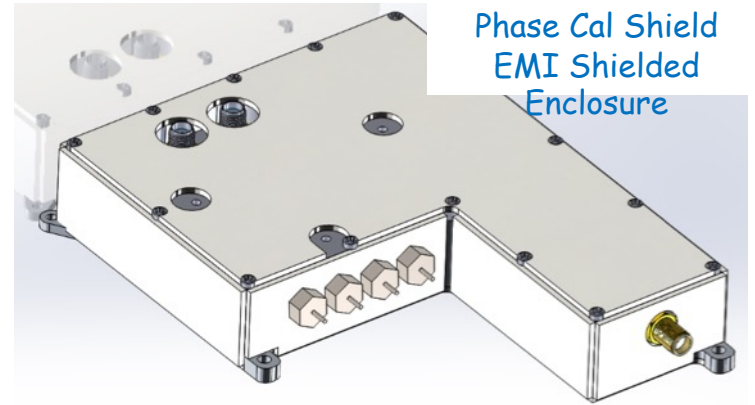
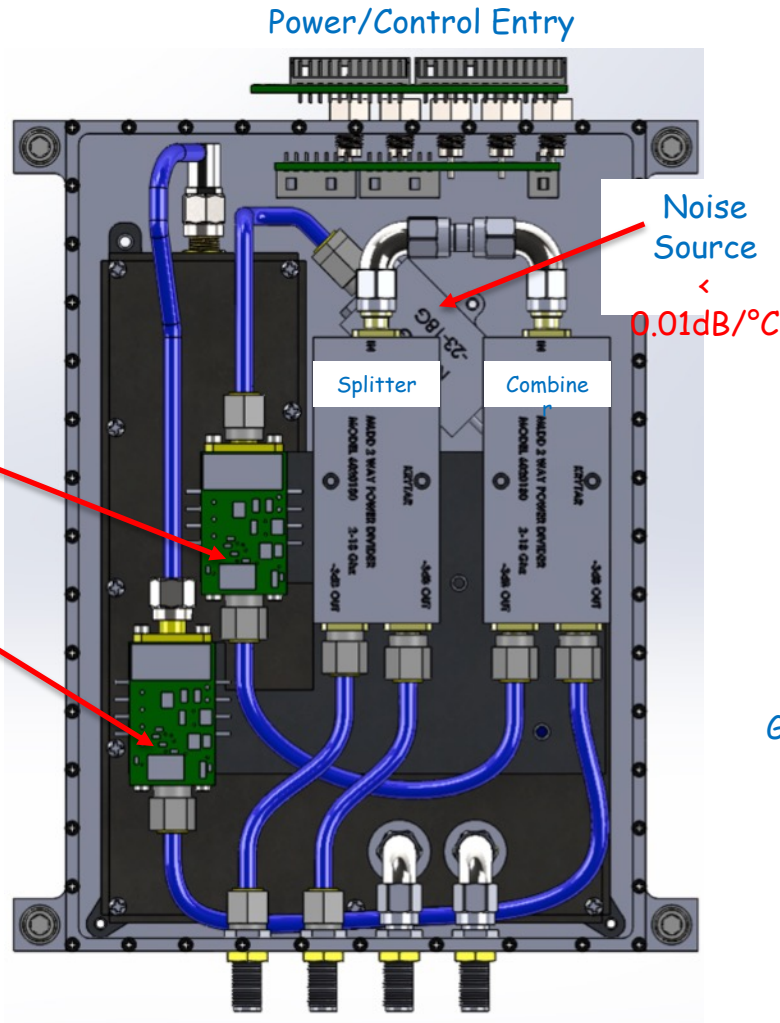

Calibration - Ground Unit

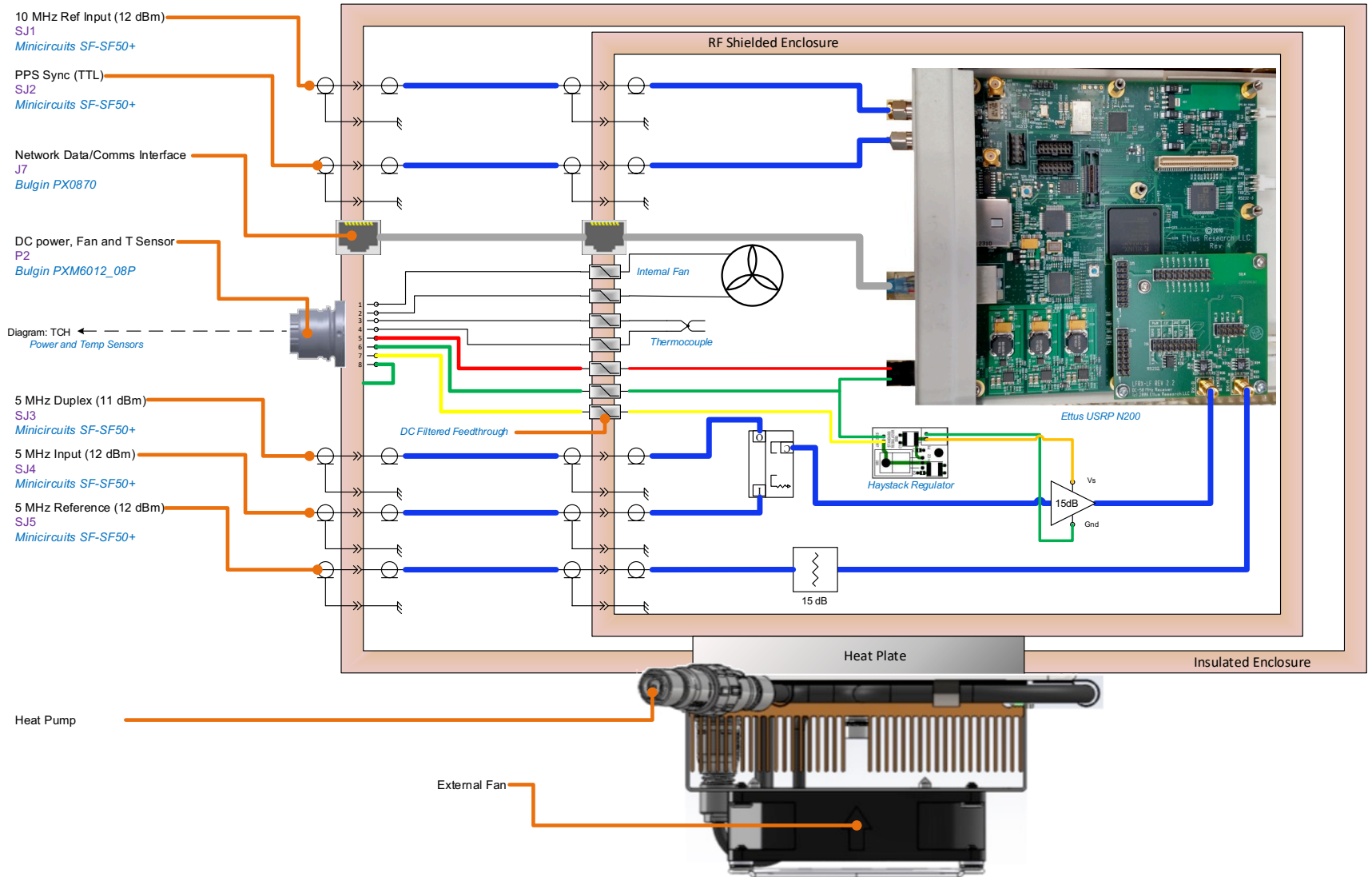

What is phase cal phase sensitive to?

- Phase cal phase, measured at baseband, depends on:
 - 5 MHz phase at output of “ground unit” in control room
 - Electrical length of cable up to antenna unit
 - Phase delay through antenna unit
 - Phase delay from antenna unit to cal injection point
 - Phase of receiver LO
 - Phase delay through receiver, from cal injection point to IF output
 - Electrical length of IF cable from receiver to control room
 - Phase delay through backend electronics (e.g., IF up- or down-converter, IF distributor, VC/BBC)
 - LO phase in backend mixers
- Any instrumental phase/delay that affects quasar (fringe) signal also affects phase cal signal except for
 - delay through antenna structure and
 - delay from feed to cal injection point.

What is phase cal amplitude sensitive to?

- Phase cal amplitude, as measured in baseband, depends on:
 - Phase cal voltage at antenna unit output
 - Loss between antenna unit and cal injection coupler
 - Coupling strength of cal injection coupler
 - Gain/loss through receiver, antenna cables, and backend
 - Coherence loss due to unstable LO in receiver or backend
 - Reflections in RF or IF path from antenna unit to backend
 - USB/LSB image rejection in downconverters (legacy S/X mainly)
 - Interference from spurious signals
- Phase cal amplitude, as measured in **digital** bit stream (sign bit or 2 bits with AGC), is the ratio between the analog phase cal amplitude and rms noise voltage.
 - Normalizing by the noise voltage makes the digital phase cal amplitude
 - insensitive to gain/loss through the receiver and backend (item 4 above), but now
 - sensitive to system temperature (including increase due to RFI).

Phase cal applications

- Measure changes in instrumental phase/delay during and between scans.
 - Example: Change in antenna RF/IF cable length at some antenna orientations.

phase cal
delay

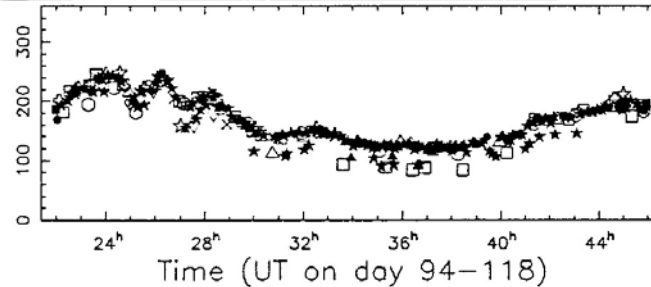

- Improve fringe phase coherence by correcting for LO phase variations
 - Example: Correction of LO jumps caused by intermittent cable connection.

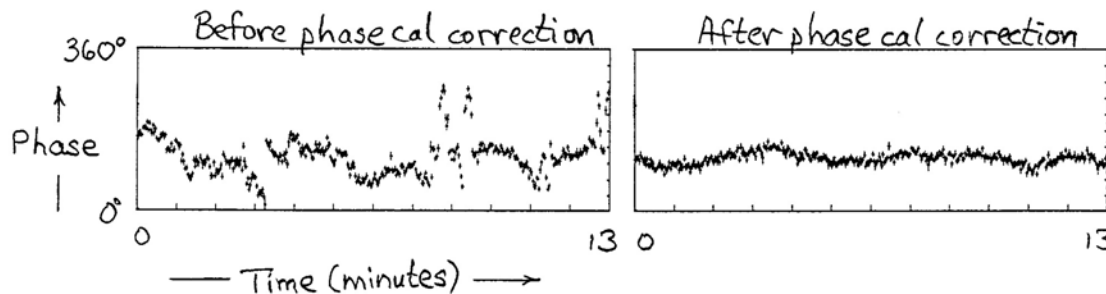

- Check for LO modulation sidebands that can degrade phase coherence and VLBI sensitivity.
- Test USB/LSB image rejection in downconverters, if still in use.

Spurious phase cal signals

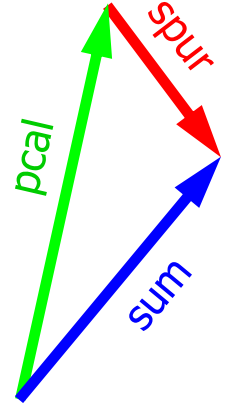

- Definition: Spurious signal is a monochromatic signal
 - at the same RF, IF, or baseband frequency as a pcal tone
 - coherent over at least ~1 second with the pcal tone
 - but not the pcal signal that traversed the desired signal path.
- Spurs corrupt measured phase cal phase and amplitude.
 - For a -20 dBc spur, error in measured pcal signal is up to
 - 6° in phase \leftrightarrow 33 ps over 500 MHz
 - 10% in amplitude
- Examples of spurious signal sources:
 - Maser-locked signals generated in VLBI electronics (e.g., 5 MHz harmonics)
 - Phase cal images
 - Phase cal intermodulation/saturation
 - Secondary injection paths from pulse generator
 - Multipath from radiated phase cal
 - Cross-talk from other polarization
- Goal: Spurious signals >40 dB weaker than phase cal.
- For details, see pages 31-35 of
<ftp://ivsc.gsfc.nasa.gov/pub/TOW/tow2013/notebook/Corey.MW2.pdf>



Diagnostic tests for spurious signals

- At a station -
 - Measure power level of a pcal tone on a spectrum analyzer.
 - Observe how far the level drops when steps are taken that **should** make pcal completely disappear. Examples:
 - Disconnect reference signal to pcal antenna unit.
 - Turn off pcal with ground unit switch (Mark4 cable cal systems).
 - Unlock receiver LO.
 - Offset receiver LO frequency from integer MHz.
 - Disconnect cable from antenna unit to cal injection coupler.
 - Level should drop >40 dB.
 - Analyzer resolution BW < 100 mHz may be needed to keep analyzer noise floor low enough to see a 40 dB drop.
- At a station or a correlator -
 - Plot pcal amplitude vs. pcal phase for pcal data extracted from recordings for many observations.
 - Look for quasi-sinusoidal pattern in amp vs. phase plot.

Origin of pcal amp vs. phase quasi-sinusoids

- Legend:
-  True phase cal, rotated in steps of 90°
 -  Spurious signal
 -  Vector sum of true phase cal & spurious signal

- Case 1: Spurious signal of constant amplitude and phase
 - Amplitude of vector sum varies by one cycle as pcal phase varies 360° .

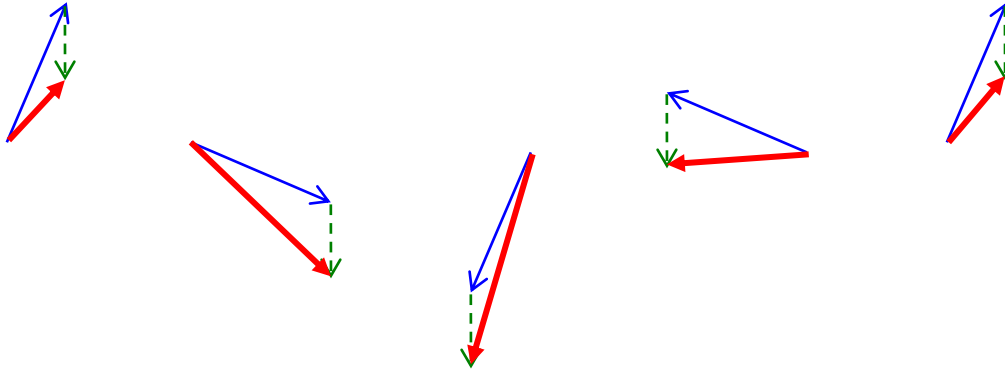

- Case 2: Spurious signal = phase cal at image frequency
 - Amplitude of vector sum varies by two cycles as pcal phase varies 360° .

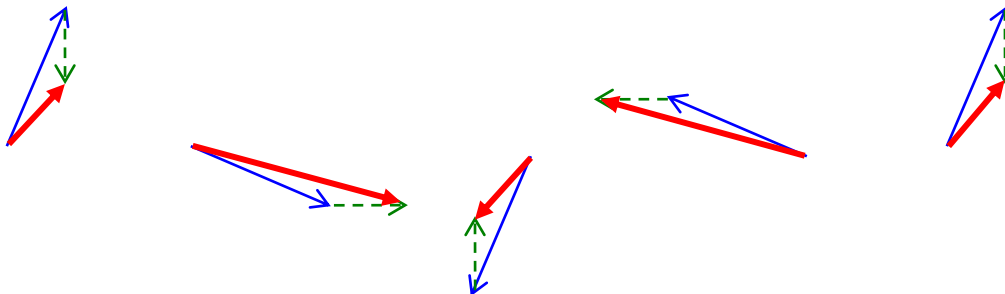

Spurious signal example: constant spur

Theory:

Pcal constant spur model for true pcal amp = 100 and spur amp = 10

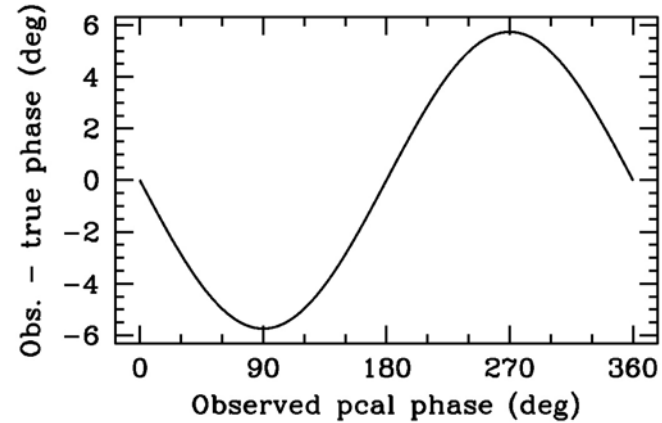
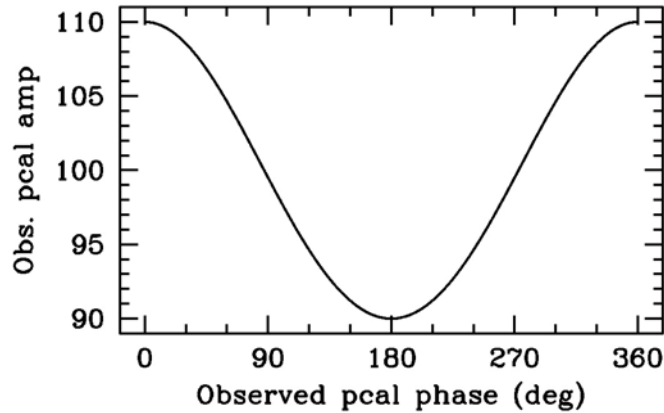

Observation:

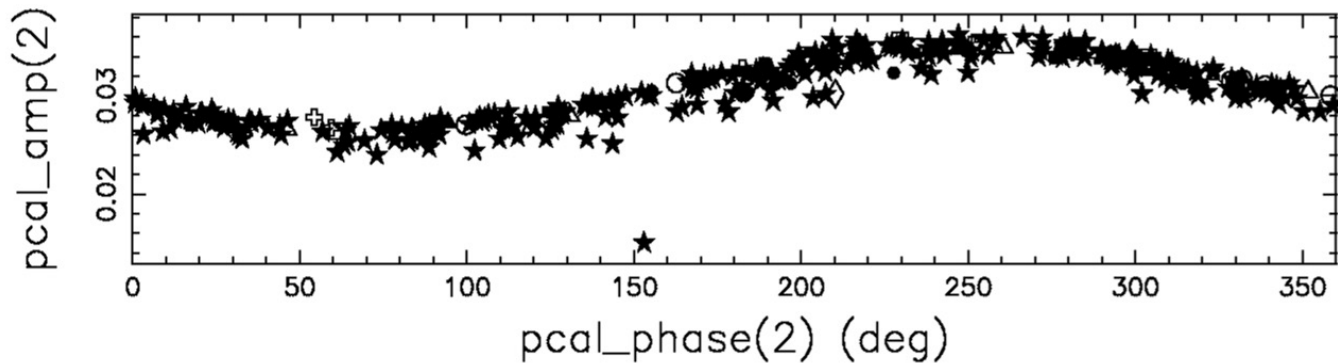

Spurious signal example: image spur

Theory:

Pcal image spur model with pcal amp = 100 and image amp = 50

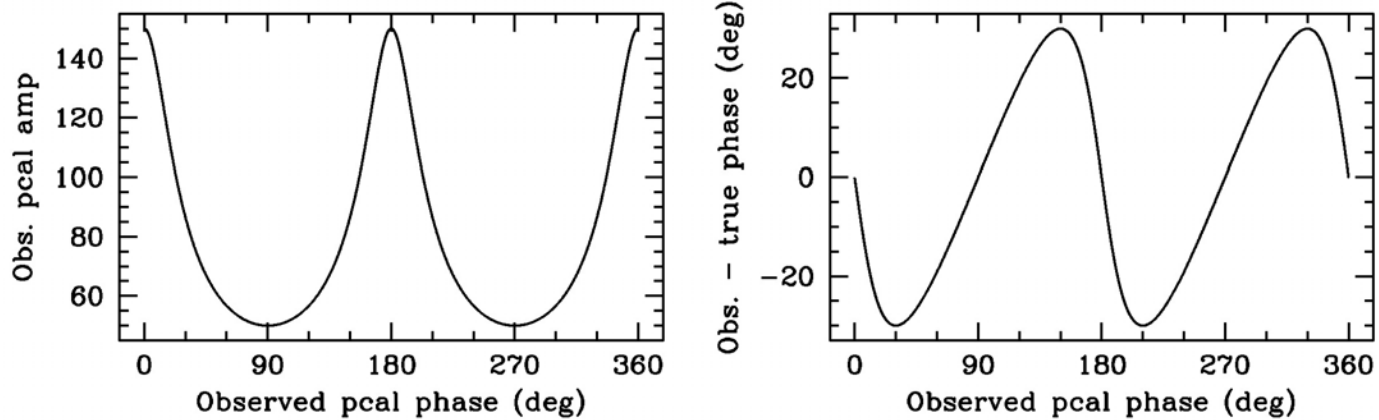

Observation:

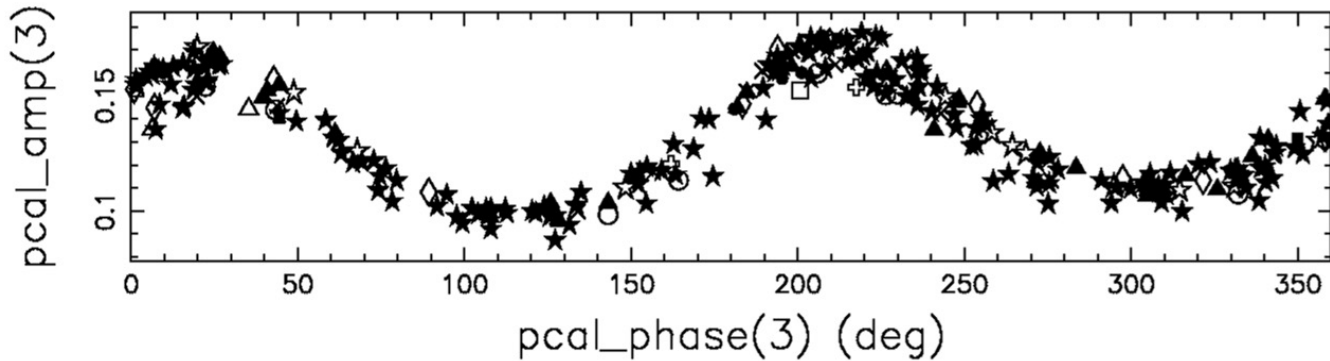

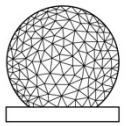

Simulation of raw VGOS data with phase cal tones

(Gruber, J., Nothnagel, A. and Böhm, J. (2021) 'VieRDS: A Software to Simulate Raw Telescope Data for very Long Baseline Interferometry', *\pasp*, 133(1022), p. 44503.
doi: 10.1088/1538-3873/abeca4.

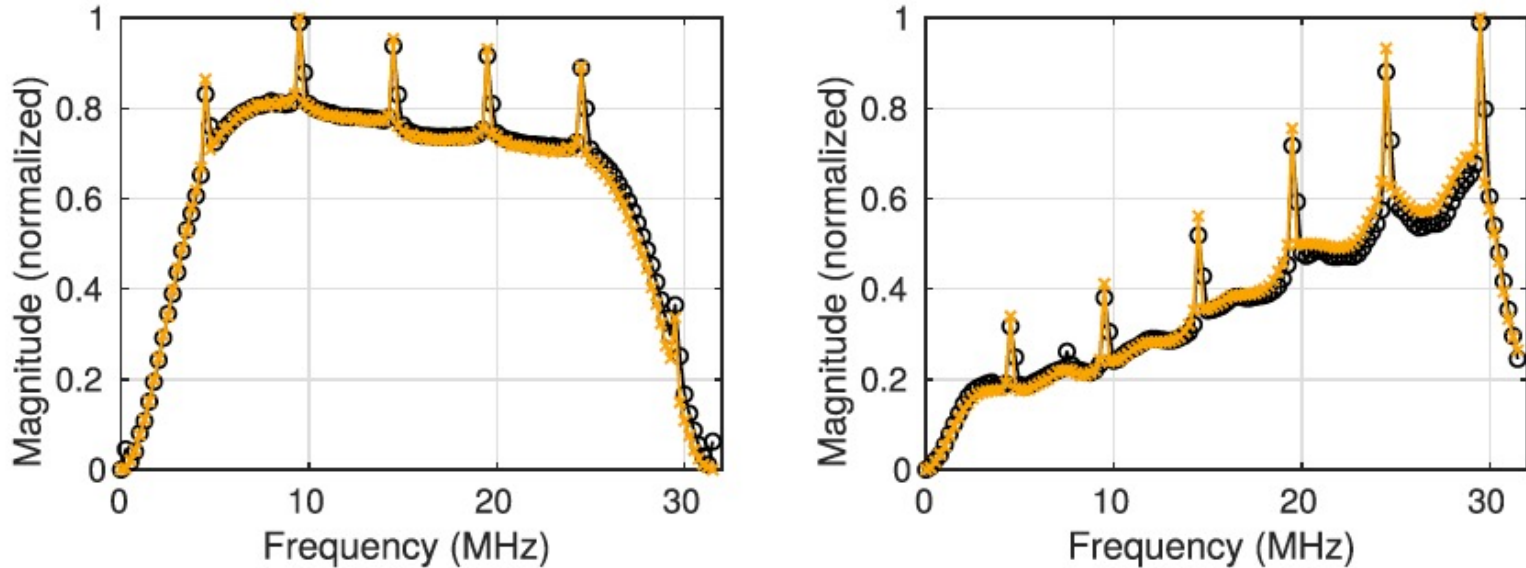
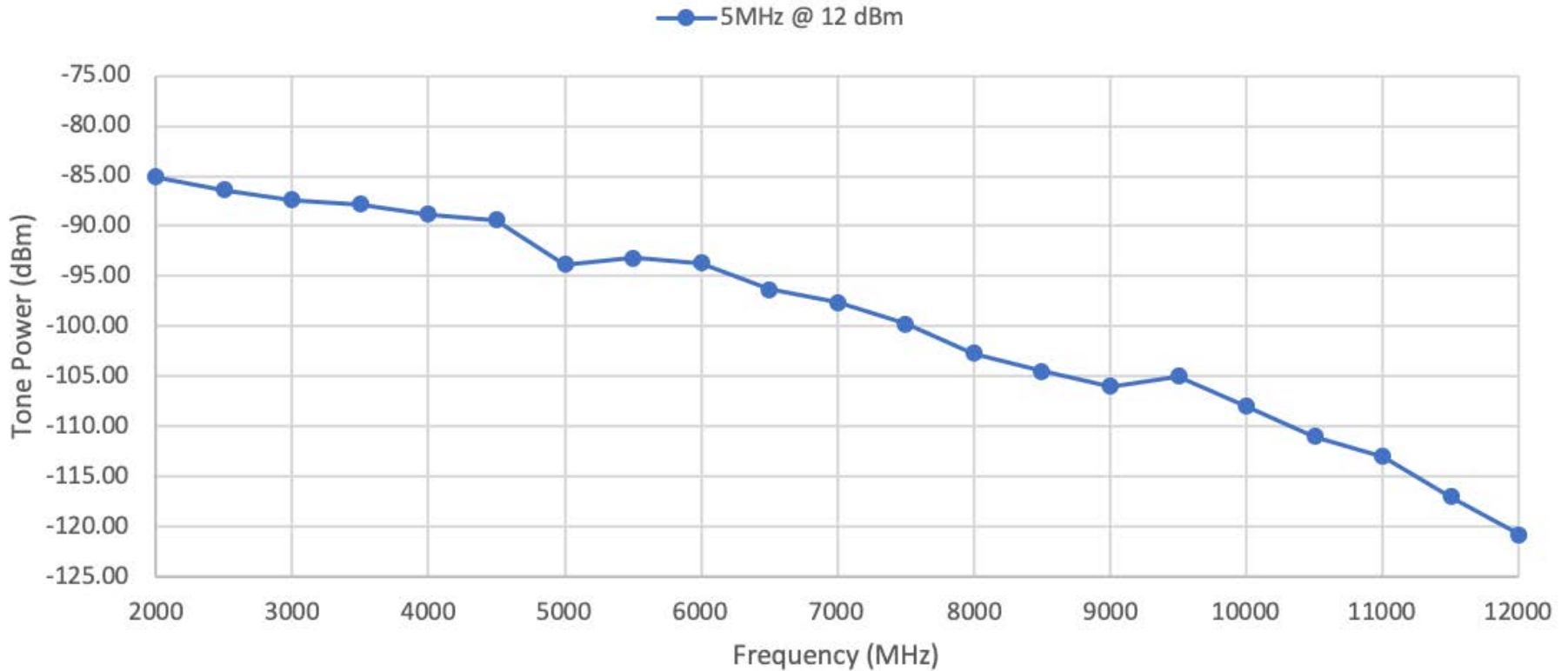
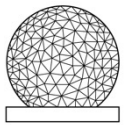

Figure 5. VieRDS is designed to simulate the characteristic frequency response of VLBI radio telescopes. The magnitudes of the frequency response of a 32 MHz channel for KOKEE12M (left) and WETTZ13S (right) is shown. The real observed frequency response is depicted in black color, whereas the simulated frequency response is depicted in orange color. The characteristic bandpass frequency response is clearly visible for both, real and simulated data, and reflects the characteristic bandpass response per station. The difference between real and simulated data is comparably small. Furthermore, the phase calibration signal with tones every 5 MHz are clearly visible for real and simulated data.

How to measure and adjust pCal to noise power ratio ?

MGO CDMS-AU Pcal Tone Amplitudes measured in narrow band mode (10KHz span) +12dBm 5MHz input level





How to measure and adjust pCal to noise power ratio ?

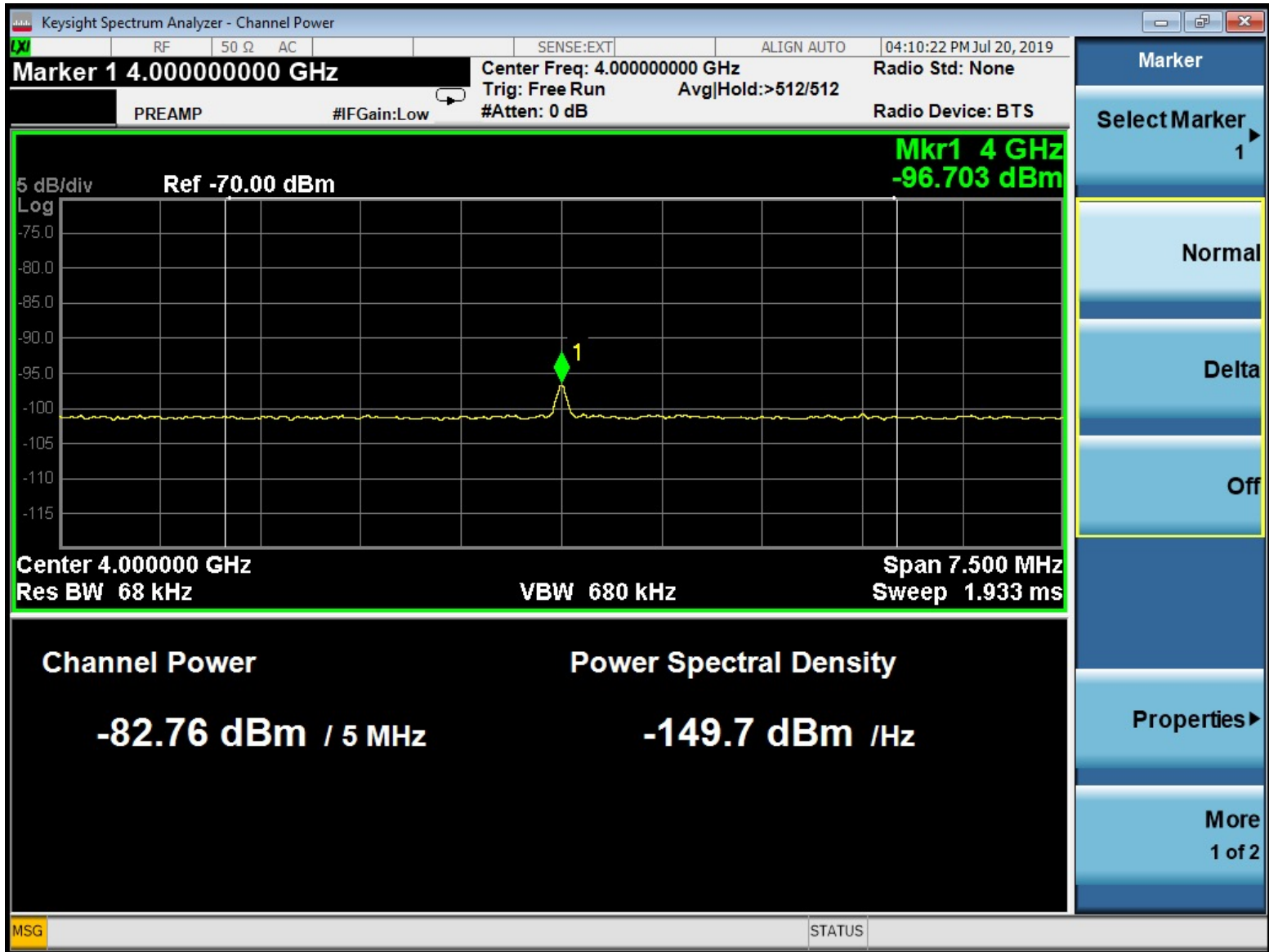

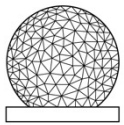

More accurate measurement of a single pCal tone

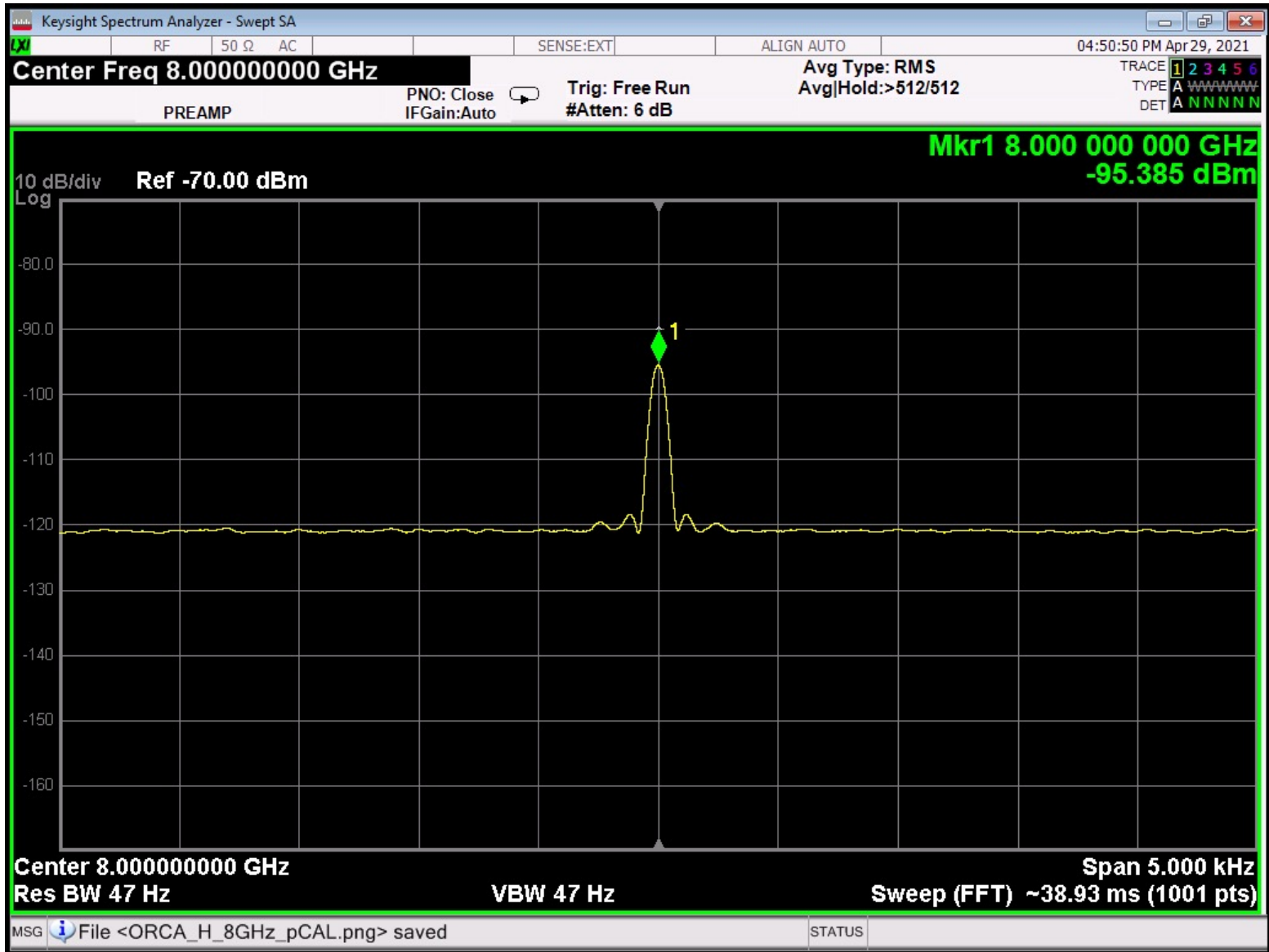

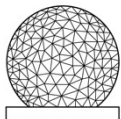

5 MHz noise power using Channel Power mode

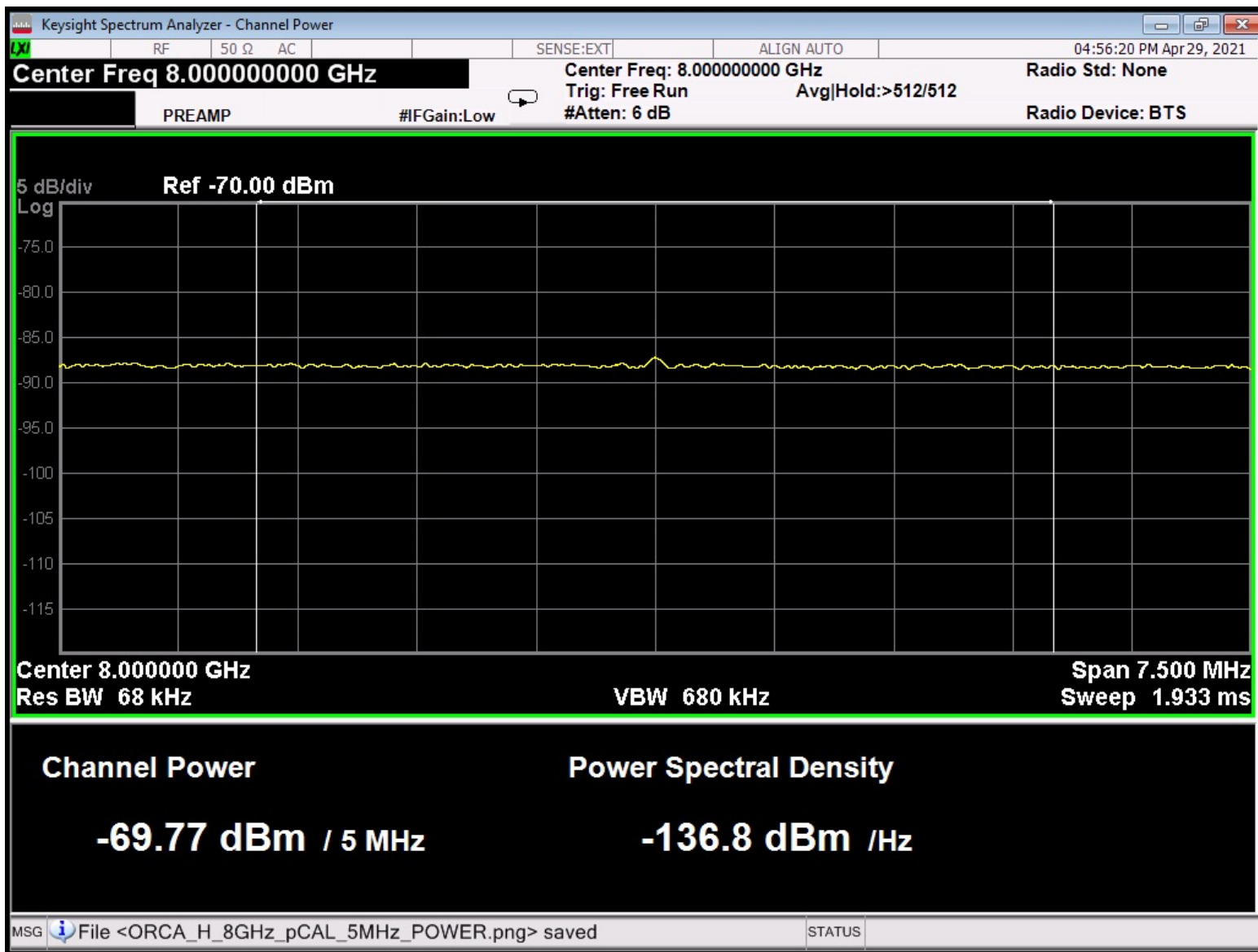

PCAL power: 'sweet area'

VieRDS (PCAL) → DIFX → HOPS (PCAL phase, SNR)

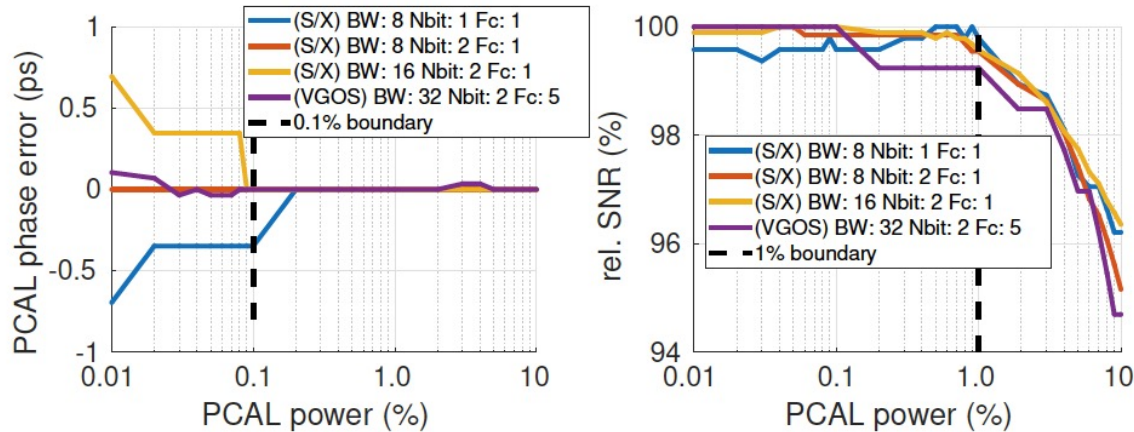

Interesting PCAL power thresholds: 0.1 % and 1.0 %

Below 0.1 %: the PCAL phase measurements show significant errors.
Above 1.0 %: SNR of the quasar noise signal is decreased.

pCal peak power ratio from MIT Haystack Signal Chain NASA MGO VGOS Station 20-July-2019

● %
 ● pCal peak (dBm)
 ● 5MHz noise power (dBm)

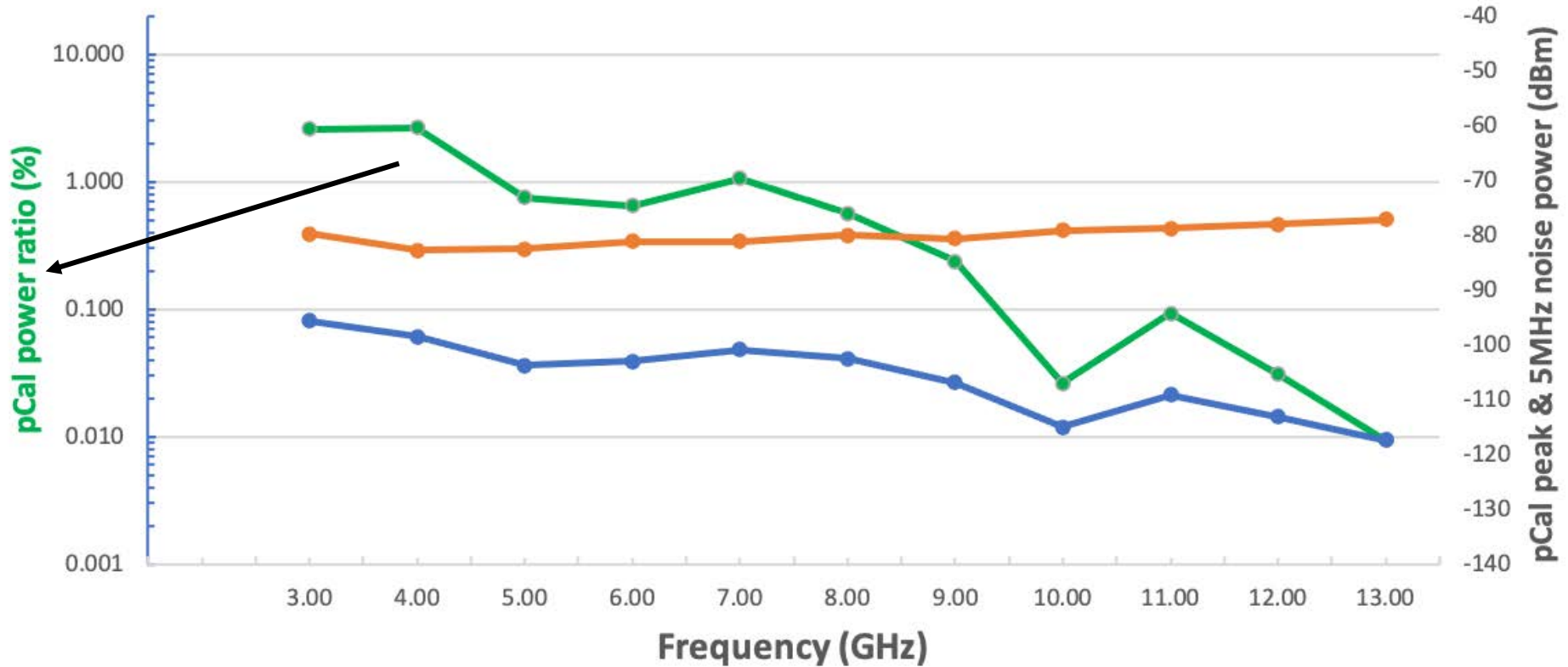

Why cable calibration?

- Where is the VLBI station?
 - On the antenna, at the intersection of axes,
 - not at the backend or maser.
- For absolute UT1 (= Earth rotation angle relative to Universe) measurements, absolute length of uplink and downlink must be measured.
 - We're not doing absolute (yet), so relax!
- For relative UT1 & other geodetic measurements, only variations in downlink (measured with phase cal) and uplink must be accounted for.
- Electrical length of uplink must be
 - stable or, if not,
 - measured for post-observation correction.

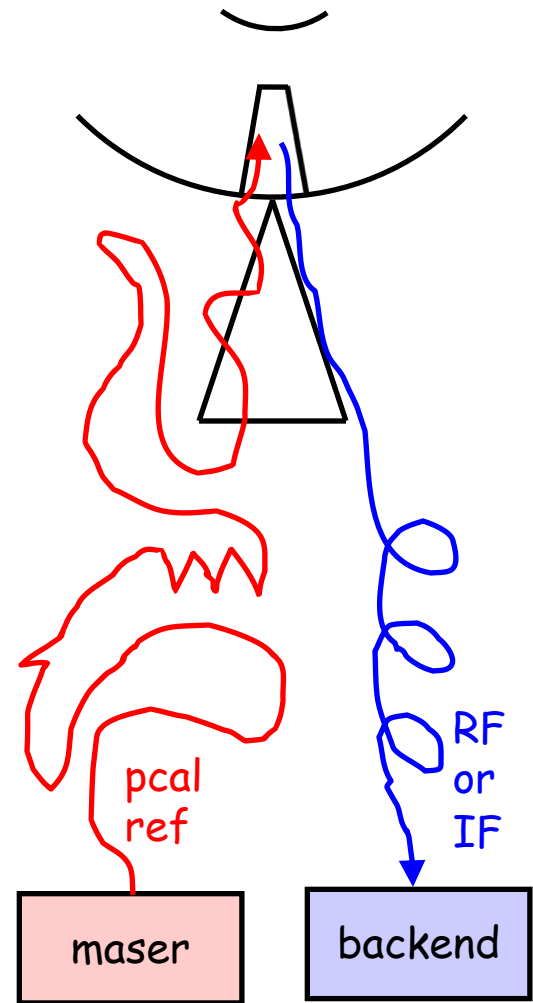

- Measurement techniques include:
 - Use vector voltmeter in control room to measure phase difference between reference signals sent to receiver and returned from receiver.
 - If a single cable is used for transmitting both directions, reflections along the way can cause measurement errors.
 - If two cables are used, they may not behave in same manner.
 - Modulate reference signal in antenna unit before returning it to control room, to distinguish it from a reflected signal.
 - This is method used in Mark4 cable cal system.
- A cable measurement system is certainly needed for VGOS systems with a coaxial cable uplink.
 - VGOS limit on orientation-dependent uplink cable delay variations = <0.3 ps
 - Observed delay variations in RG-214 and LMR-400UF 5 MHz cables on GGAO and Westford antennas are $>\sim 1$ ps at best, and can increase over time.
- KPGO & MGO Signal Chains incorporate the new integrated calibrator module and cable delay is used in deriving the geodetic results.

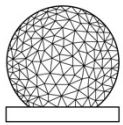

Representative cable cal systems deployed

- Some systems stabilize the transmitted phase rather than measure variations.
- Most optical fiber systems send the same frequency up and down separate fibers due to directional crosstalk in a single fiber.
 - Do lengths of up and down fibers change by the same amount?
 - Possible to use WDM on one fiber -send at one wavelength & receive at another

<i>System</i>	<i>Cable no./type</i>	<i>Frequencies</i>	<i>Comments</i>
Mark 4	1 coax	5 MHz & 5 kHz	Does not meet VGOS spec.
VLBA	2 coax	500 MHz & 2 kHz	Modulates 500 MHz in frontend.
Koike Park	2 fibers	500 MHz	
NRAO 14-m	2 fibers	500 MHz	
JPL DSN	1 fiber	modulated 1 GHz	Phase stabilization
EVLA	2 fibers	512 MHz	
Arecibo	2 fibers	1.45 GHz	
KVG	1 coax or fiber	2 near 700 MHz	Phase stabilization or meas.
NASA VGOS	1 coax or fiber	5 MHz	In operation at Koike Park, OSO, MGO

- MIT Haystack Mark 5 development Memo series
(<https://www.haystack.mit.edu/haystack-memo-series/mark-5-memos/>)
 - Mk5-020 Simulation of phase cal and low fringe rate phase error using a polyphase filter bank
 - Mk5-021 Phase Cal Extraction for the Mark 5B
 - Mk5-051 Measurements of cross-talk and spurious signals levels aer
 - Mk5-065 Proposed phase calibration scheme
 - Mk5-066 Measurements of cable delay with temperature and flexure
 - Mk5-071 Test of Hittite Logic gate
 - Mk5-074 Phase calibrator pulse distortion in UDC
 - Mk5-075 Preliminary circuit for the new phase cal
- MIT Haystack Broadband Memo series
(<https://www.haystack.mit.edu/haystack-memo-series/vgos-memos/>)
 - BBDev-017 Modification to NASA/Honeywell pcal for 5 MHz repetition rate
 - BBDev-021 Phase cal performance during 2008 May 23 GGAO-Westford BBD test
 - BBDev-023 Tests of new "digital" phase calibrator
 - BBDev-031 Notes on phase cal extraction, power levels, total rail count, and SNR
 - BBDev-032 Phase Cal Channel-to-Channel Phase Discontinuities
 - BBDev-034 Phase Cal Amplitude RF Frequency Dependence

What does pCal not correct ?

Delays ahead of pcal injection are not calibrated and must be determined from the data (Y-X offsets).

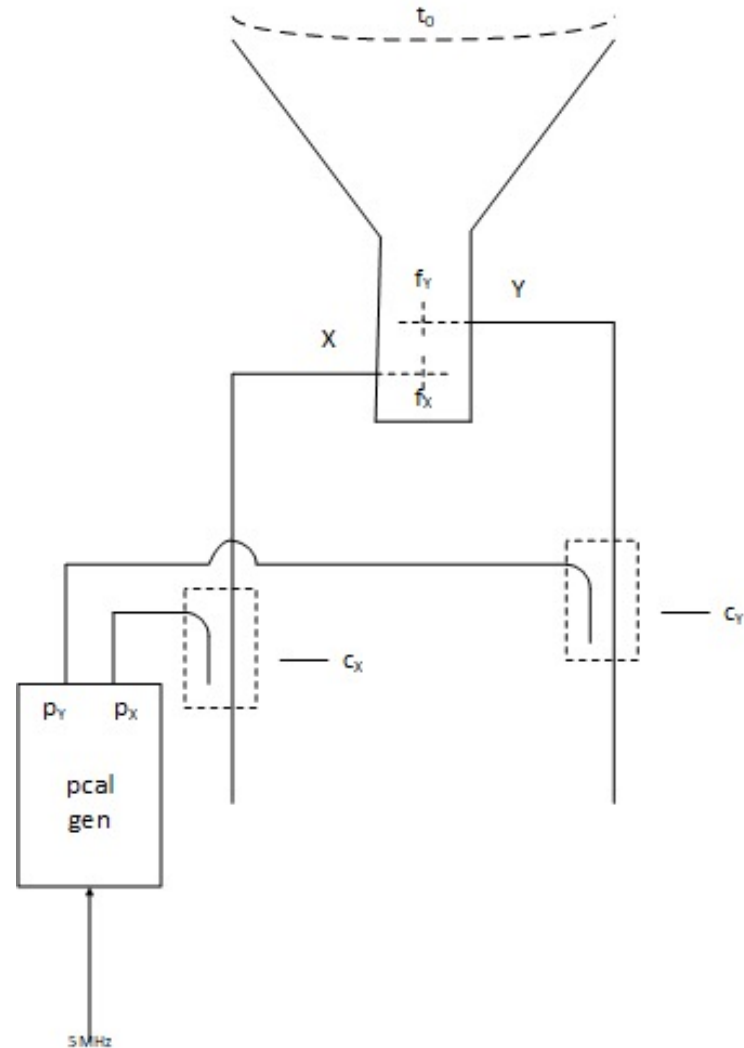

More online resources

- For more advanced treatment of the subject, refer to notes and presentations from
 - VGOS Correlation Workshop, Thursday May 9th and 10th, 2019
 - <https://www.haystack.mit.edu/conference-2/past-conferences/10th-ivs-technical-operations-workshop/>
 - A. Neill on "Phase cal and sampler delays"
- Presentations at IVS VLBI 2010 Workshop on "Future Radio Frequencies and Feeds held at Wettzell / Hoellenstein (Germany), March 18 - 20, 2009"
 - <http://www.wettzell.ifag.de/veranstaltungen/vlbi/frff2009/frff2009.html>
 - "Broadband Delay Tutorial" by B Petrachenko
- Presentations at IVS VLBI2010 Workshop on Technical Specifications (TecSpec) Bad Kötzing/Wettzell (Germany), March 1 - 2, 2012
 - <http://www.fs.wettzell.de/veranstaltungen/vlbi/tecspec2012/index.html>

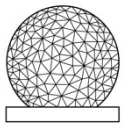

MIT
HAYSTACK
OBSERVATORY

Thank you

