

Phase Cal Basics
Cable Delay measurement System
&
A short introduction to RF system testing
using Spectrum Analyzer

Ganesh Rajagopalan & Brian Corey
MIT Haystack Observatory

Science Objectives: VLBI Geodesy

- Unique contribution to the Celestial Reference Frame (ICRF) and measurement of Earth's Orientation in Space
- Important input to the Terrestrial Reference Frame (ITRF) - scale
- Needed for precise orbit determination, spacecraft navigation, solar system exploration, astrophysics, sea level change, Earth mass exchanges, nutation

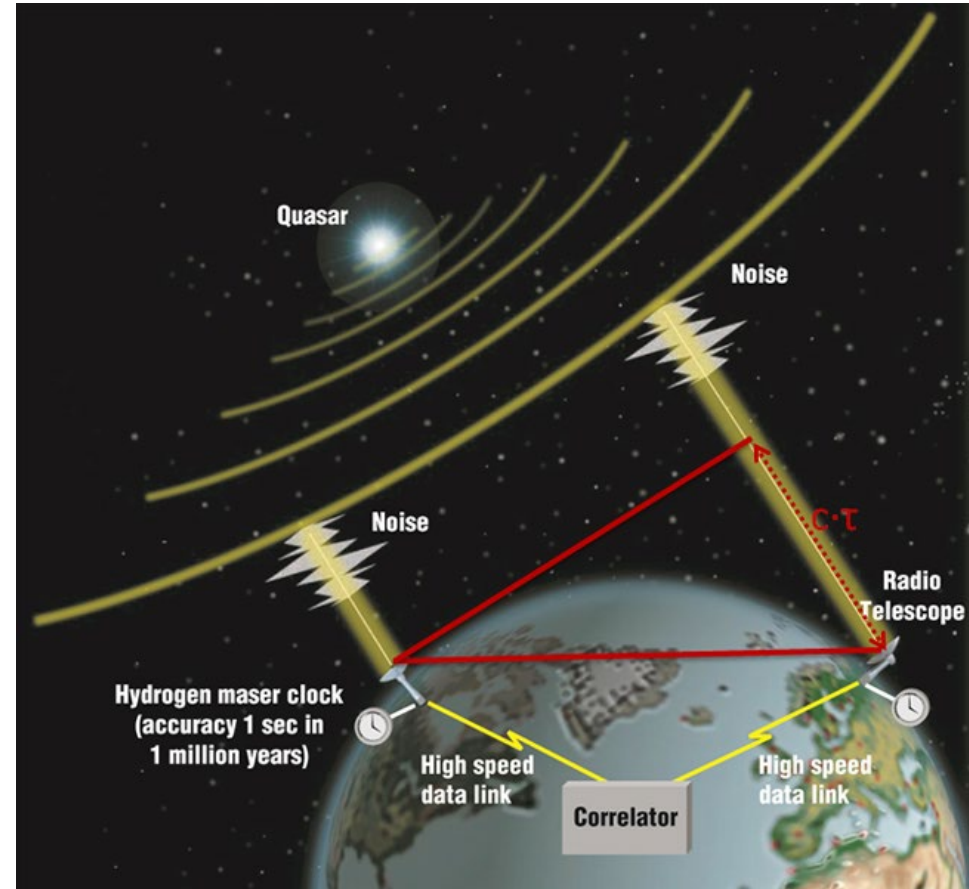

VGOS accuracy goal is 0.1 mm/yr

Phase/delay calibration systems in VLBI

- Astrometric and geodetic VLBI rely on accurate measurement of phase and delay, devoid of errors caused by instrumentation.
- In absence of perfectly stable systems, calibration signals can be used to measure, and hence correct for, instrumental time and frequency variations of phase and delay.

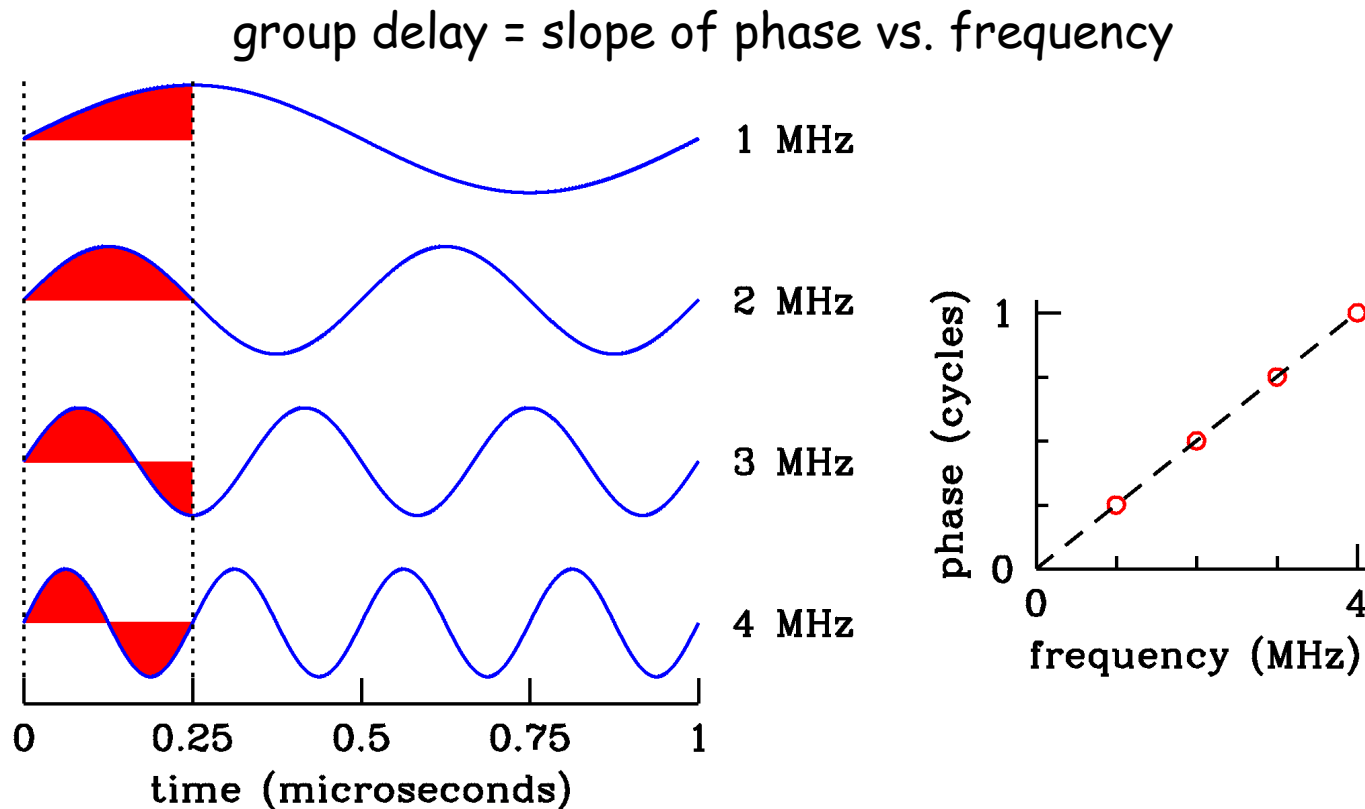

Phase calibration in VGOS

- Primary function remains as always: Measure instrumental phase variations over time and frequency.
- Phase differences between channels are far more stable in VGOS than in S/X VLBI, thanks to digital IF-to-baseband conversion in FPGAs.
- But digital back-ends have not made phase cal obsolete!
 - Phase cal needed in VGOS to measure
 - LO phase drifts between bands
 - Phase/delay drifts in RF/IF analog electronics and cables/fibers
- Increase pulse repetition rate from 1 to 5 or 10 MHz (and pcal tone spacing from 1 to 5 or 10 MHz), to reduce danger of saturation.
 - Because baseband channels are wider (~32 MHz) than in S/X, each channel will still include many pcal tones.
- Options for pcal injection point:

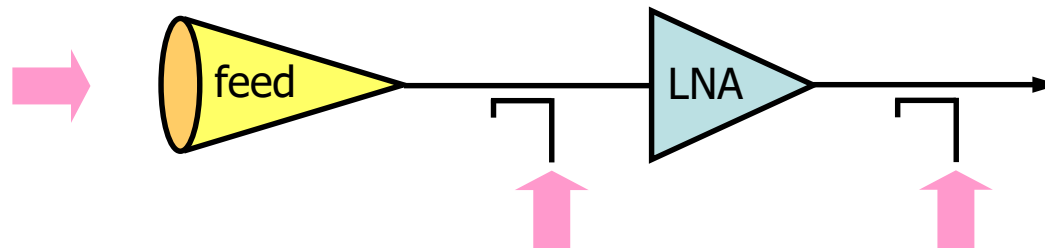

VGOS Signal Chains in the NASA network here in USA

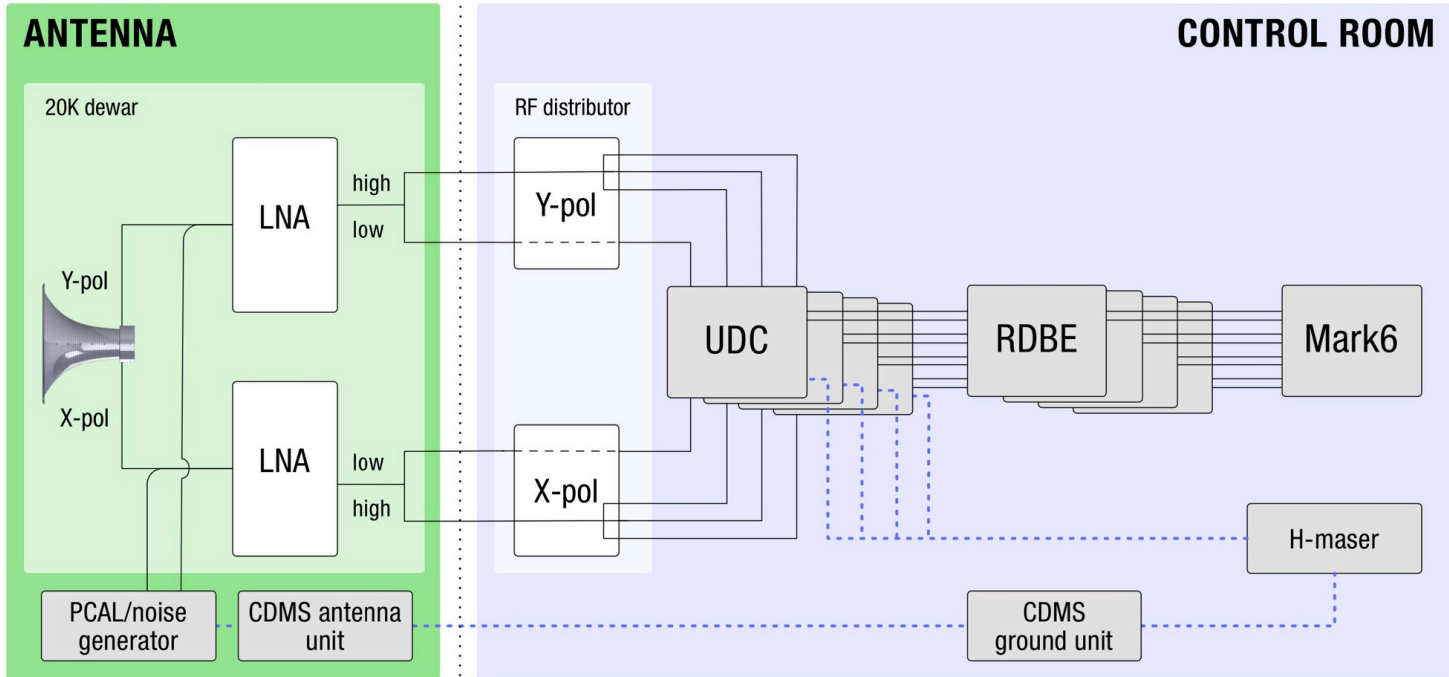
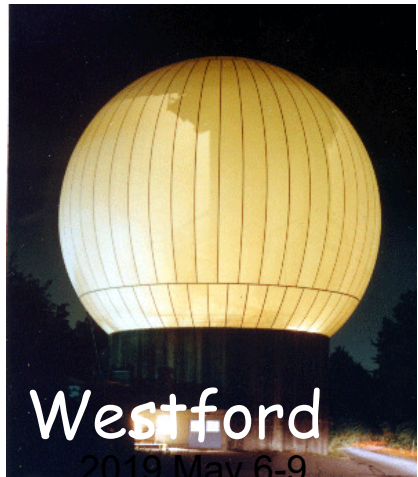

- VGOS observations use four 0.5 GHz or 1 GHz bands in the 2.2-14 GHz range
- Frequency Agile Up-Down Converter (UDC) enables tuning to different frequencies within the 2.2 to 14 GHz frequency range

Frontend

Backend

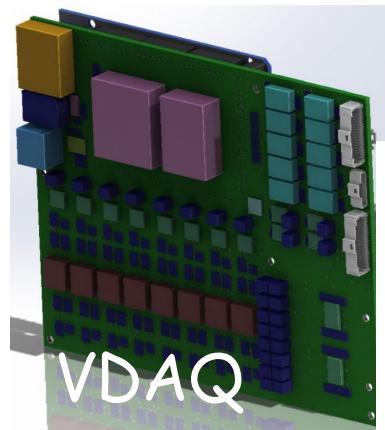
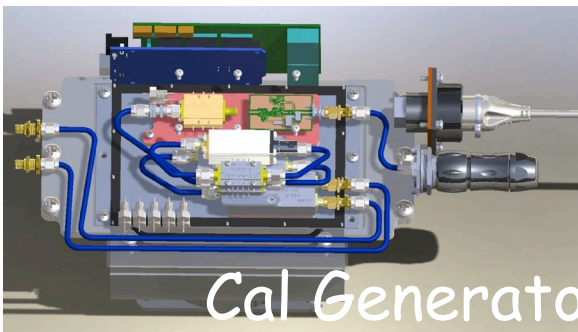
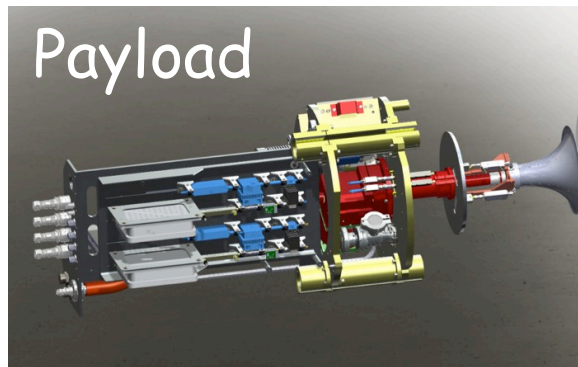
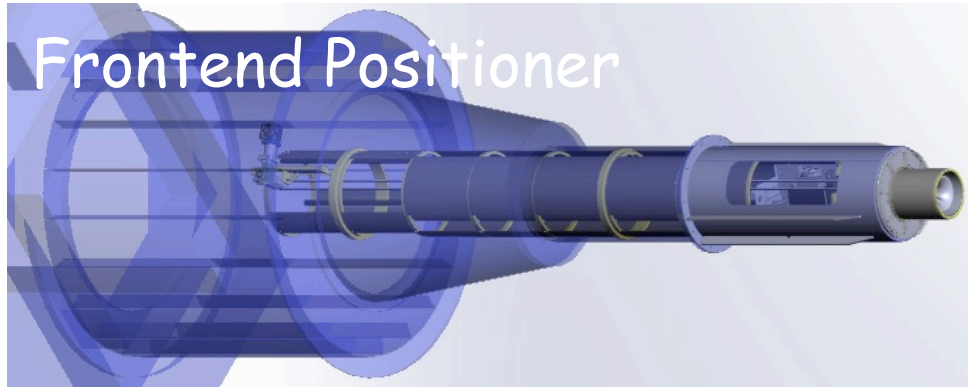

Phase cal signal in time domain, as sum of sinusoids

Say, we want a calibration signal every 1 MHz, up to 10 GHz:

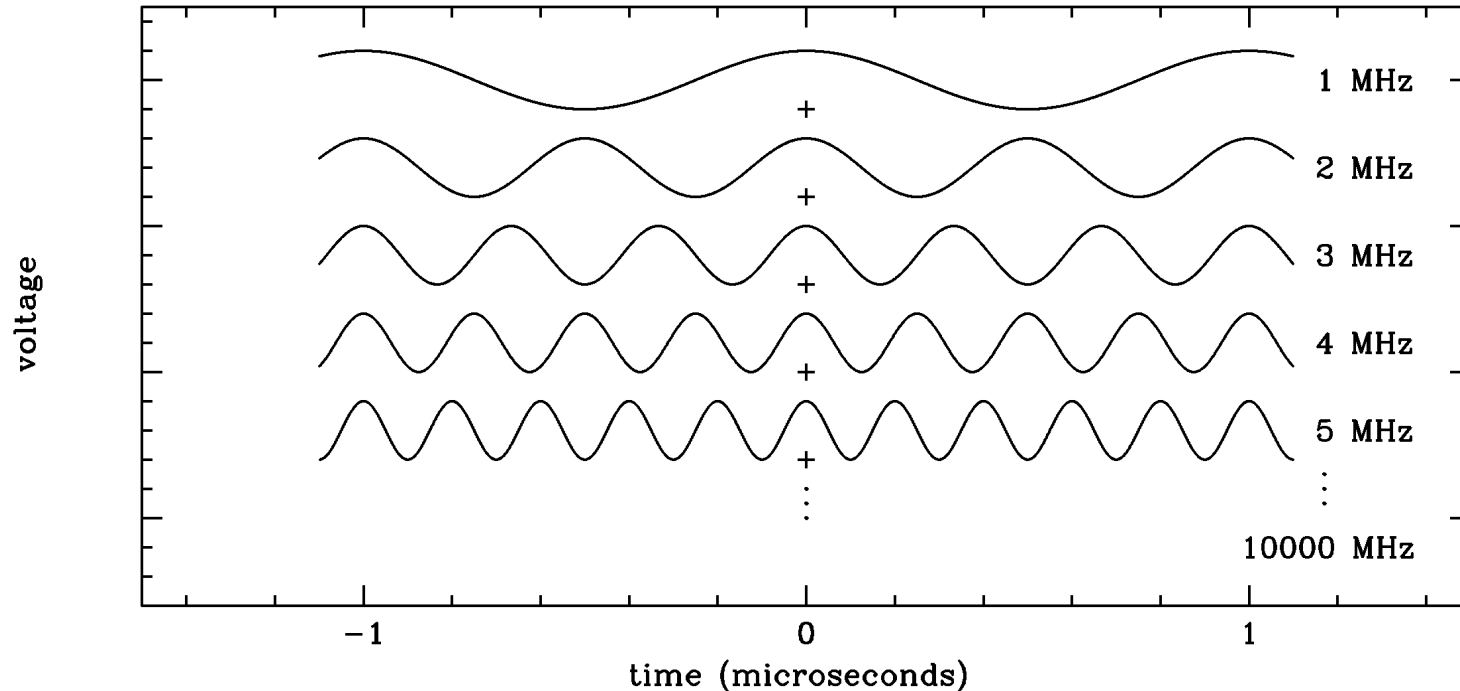

Add up all 10 000 tones and you get...

Phase cal in time domain, as pulses

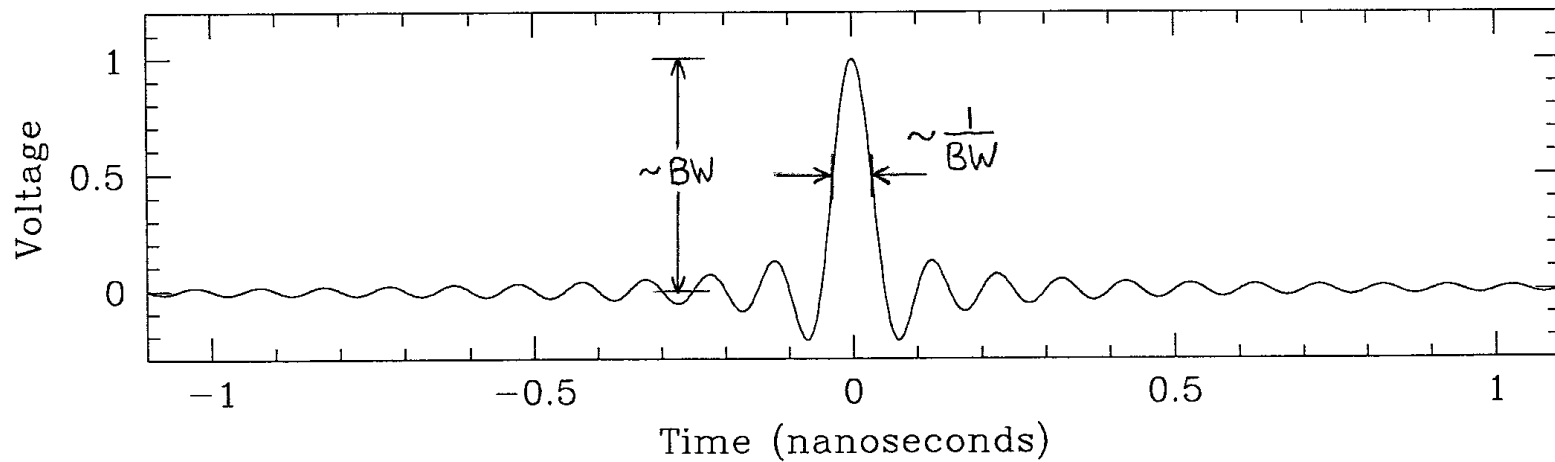
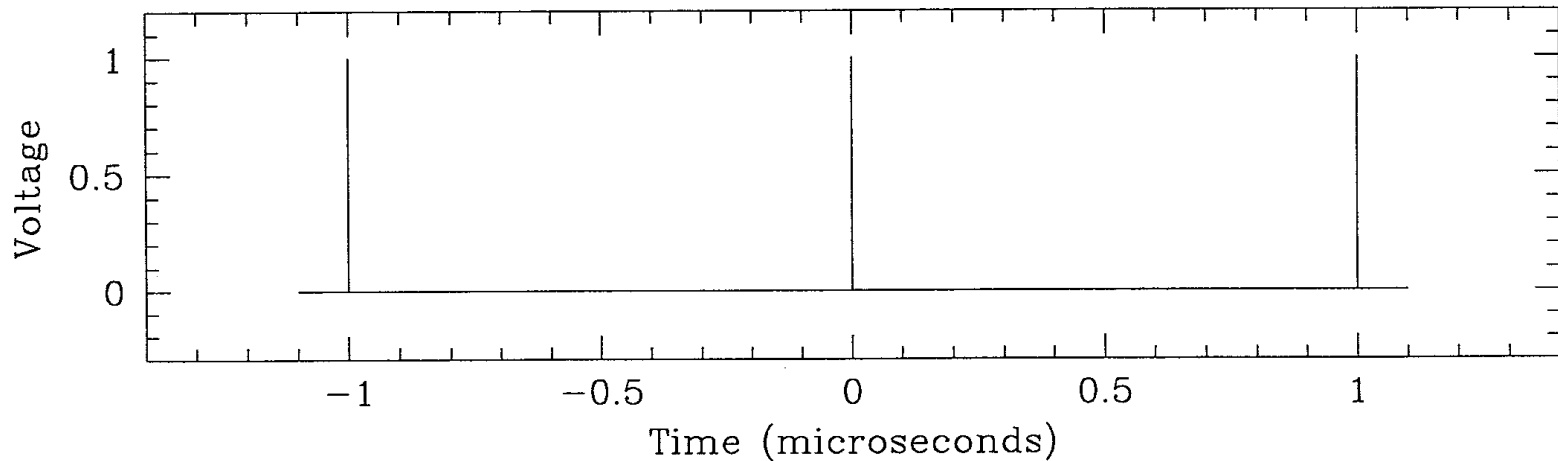

What is phase cal phase sensitive to?

- Phase cal phase, measured at baseband, depends on:
 - 5 MHz phase at output of “ground unit” in control room
 - Electrical length of cable up to antenna unit
 - Phase delay through antenna unit
 - Phase delay from antenna unit to cal injection point
 - Phase of receiver LO
 - Phase delay through receiver, from cal injection point to IF output
 - Electrical length of IF cable from receiver to control room
 - Phase delay through backend electronics (e.g., IF up- or down-converter, IF distributor, VC/BBC)
 - LO phase in backend mixers
- Any instrumental phase/delay that affects quasar (fringe) signal also affects phase cal signal except for
 - delay through antenna structure and
 - delay from feed to cal injection point.

What is phase cal amplitude sensitive to?

- Phase cal amplitude, as measured in **analog** baseband, depends on:
 - Phase cal voltage at antenna unit output
 - Loss between antenna unit and cal injection coupler
 - Coupling strength of cal injection coupler
 - Gain/loss through receiver, antenna cables, and backend
 - Coherence loss due to unstable LO in receiver or backend
 - Reflections in RF or IF path from antenna unit to backend
 - USB/LSB image rejection in downconverters
 - Interference from spurious signals
- Phase cal amplitude, as measured in **digital** bit stream (sign bit or 2 bits with AGC), is the ratio between the analog phase cal amplitude and rms noise voltage.
 - Normalizing by the noise voltage makes the digital phase cal amplitude
 - insensitive to gain/loss through the receiver and backend (item 4 above), but now
 - sensitive to system temperature (including increase due to RFI).

Phase cal applications

- Measure changes in instrumental phase/delay during and between scans.
 - Example: Change in antenna IF cable length at some antenna orientations.

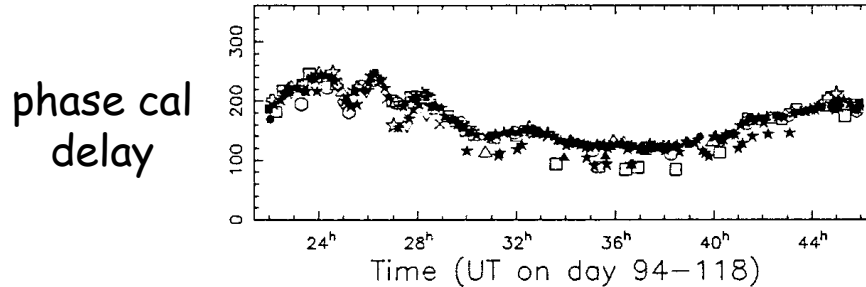

- Improve fringe phase coherence by correcting for LO phase variations
 - Example: Correction of LO jumps caused by intermittent cable connection.

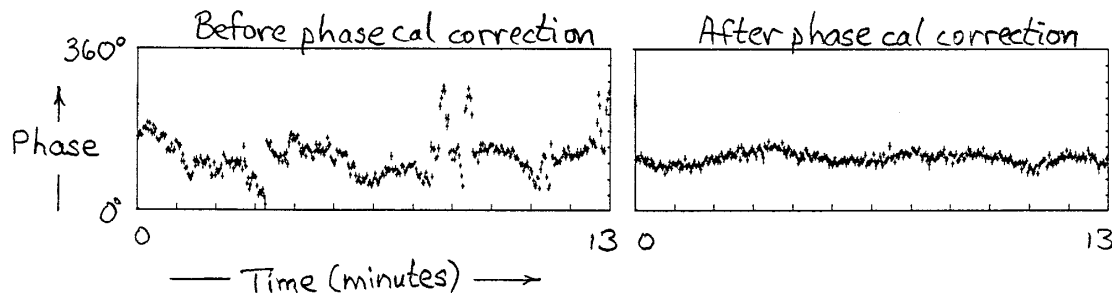

- Check for LO modulation sidebands that can degrade phase coherence and VLBI sensitivity.
- Test USB/LSB image rejection in downconverters.

Pulse repetition rate and headroom

- As RF bandwidth increases, pulse intensifies.
 - For 1-MHz pulse rep rate & 1-GHz BW, peak pulse voltage $\sim 10\times$ rms noise.
 - For VGOS RF BW of 12 GHz, peak pulse voltage $\gg 10\times$ rms noise.
- With insufficient analog headroom, pulse drives electronics into nonlinear operation. \rightarrow spurious signals generated that corrupt undistorted pcal signal
- Options to avoid driving electronics into saturation:
 - Reduce pulse strength
 - Phase cal SNR reduced \rightarrow noisier phase extraction
 - More prone to contamination by spurious signals
 - Reduce pulse strength *and* increase pulse repetition rate to 5 or 10 MHz
 - Fewer tones spaced 5 or 10 MHz apart
- With 5 or 10 MHz rep rate, baseband tone frequencies can differ from channel to channel when channel separation = 2^N MHz.
 - Fringe-fitting is more complicated if only one tone per channel is extracted.
 - Software solution: Use multiple tones per channel and correct for delay within each channel, as well as between channels.
- General recommendation: peak pcal pulse power / P1dB < -10 dB

Tunnel diode pulse generator

- 1970s-era circuit below illustrates how a 5 MHz sinewave is converted to a 1 MHz pulse train.
 - Tunnel diode creates a 5 MHz square wave with fast rise/fall.
 - Capacitor "differentiates" to make positive & negative pulses.
 - Switch passes every 5th positive pulse. → 1 MHz pulse train

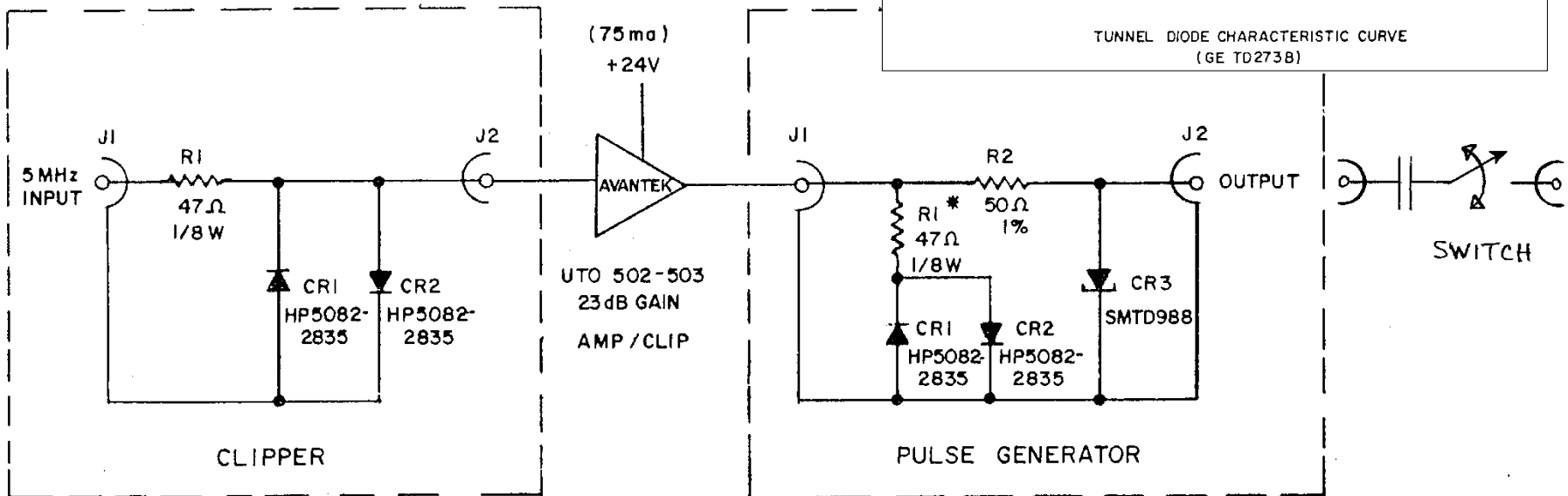
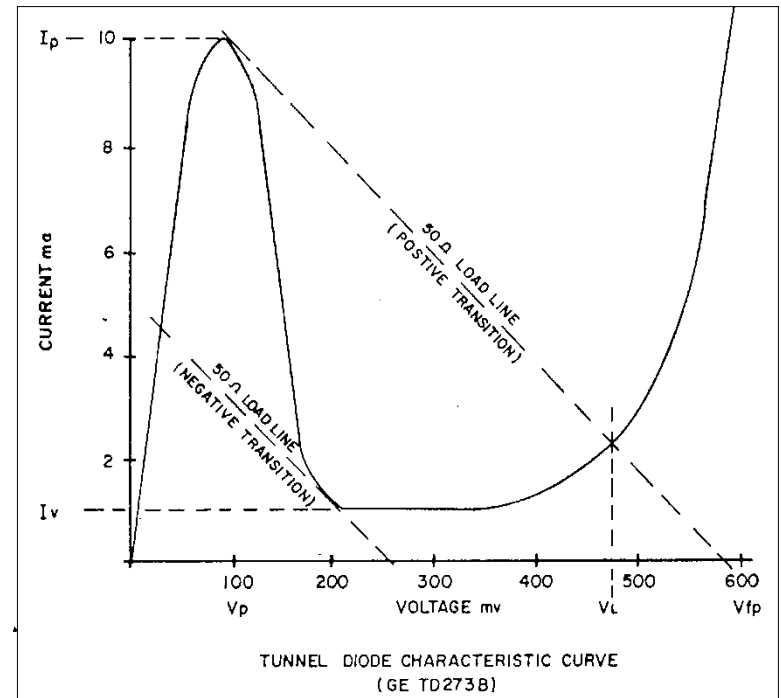

Haystack "digital" phase calibrator

- Tunnel diodes at heart of many older pulse generators are no longer available.
- High speeds of today's logic devices allow a generator to be built around them.
- "Digital" phase calibrator designed by Alan Rogers (Haystack).
- 5 or 10 MHz sinewave input; output pulse train at same frequency.
- Output spectrum flatter than in tunnel diode design.
- Pulse delay temperature sensitivity $< 1 \text{ ps}/^\circ\text{C}$ with no external temp. control.
- Support for cable measurement system.
- Circuit diagram and details available at http://www.haystack.mit.edu/geo/vlbi_td/BBDev/023.pdf.

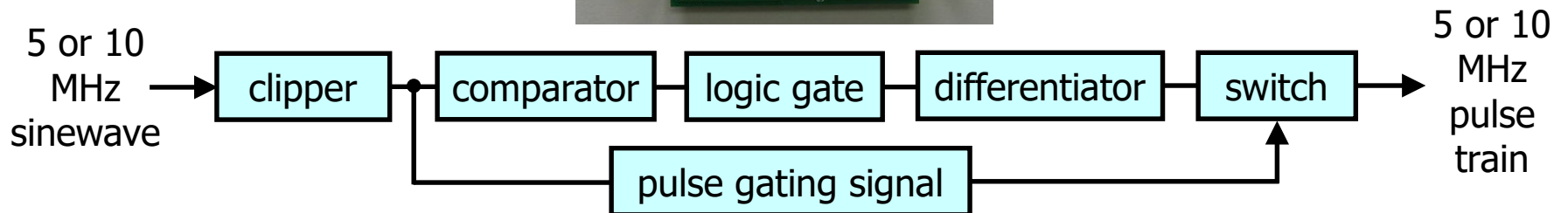
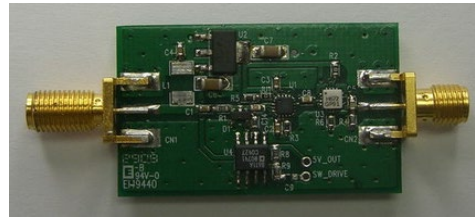

Digital phase calibrator output power spectrum

digital pcal generator tone power with 5 MHz input

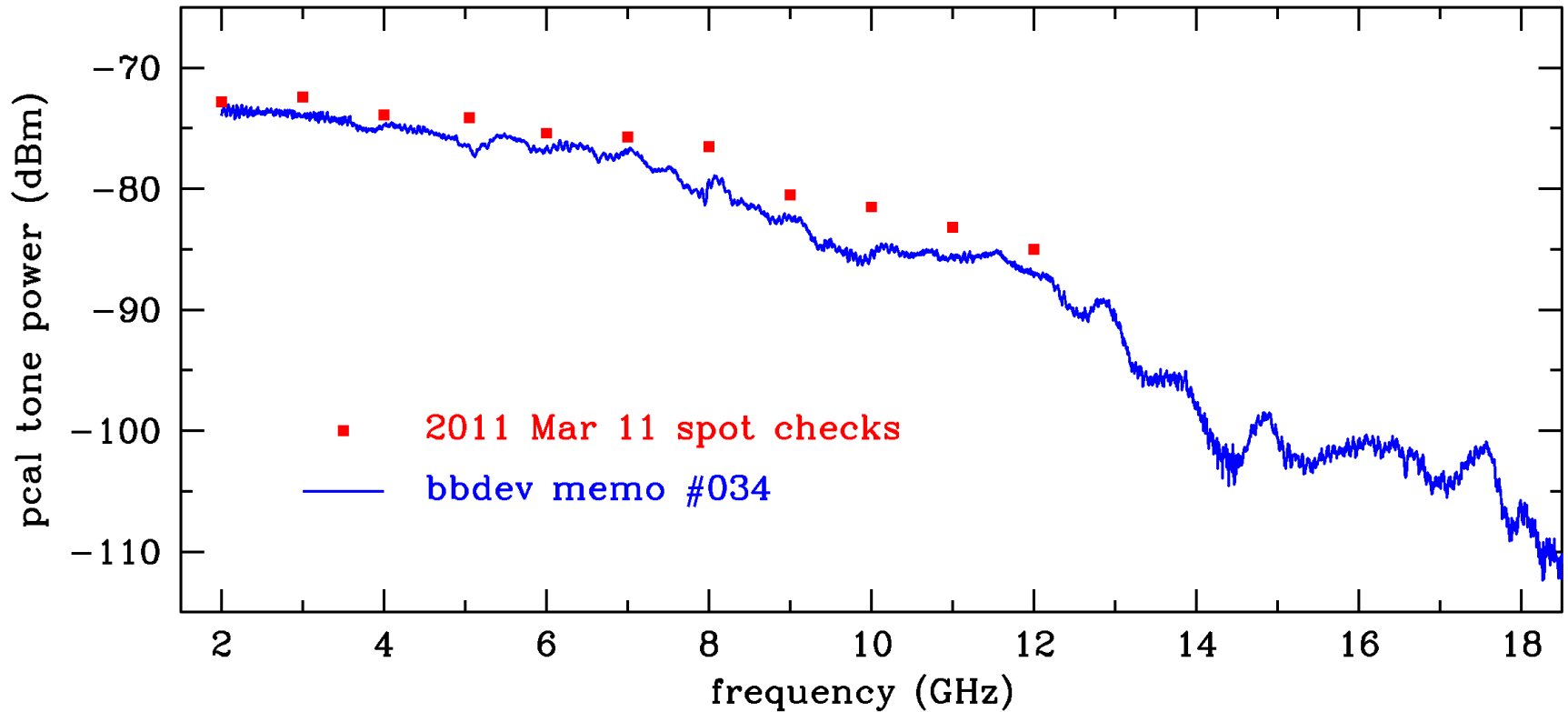

Broadband phase/noise calibration unit

- "Cal box" developed by Haystack Observatory for VGOS front-ends
- Cal box includes
 - digital phase calibrator
 - noise source
 - 0-31.5 dB programmable attenuators on phase and noise outputs
 - noise and phase cal gating
 - RF-tight enclosure
 - Peltier temperature controller ($\Delta T < 0.2^\circ\text{C}$ for 20°C change in ambient T)
 - monitoring of temperature, 5 MHz input level, attenuation, gating
- Two identical RF outputs with combined pcal+noise
- Equalizers for phase or noise cal signals can be added if necessary.

Broadband phase/noise cal box: RF connections

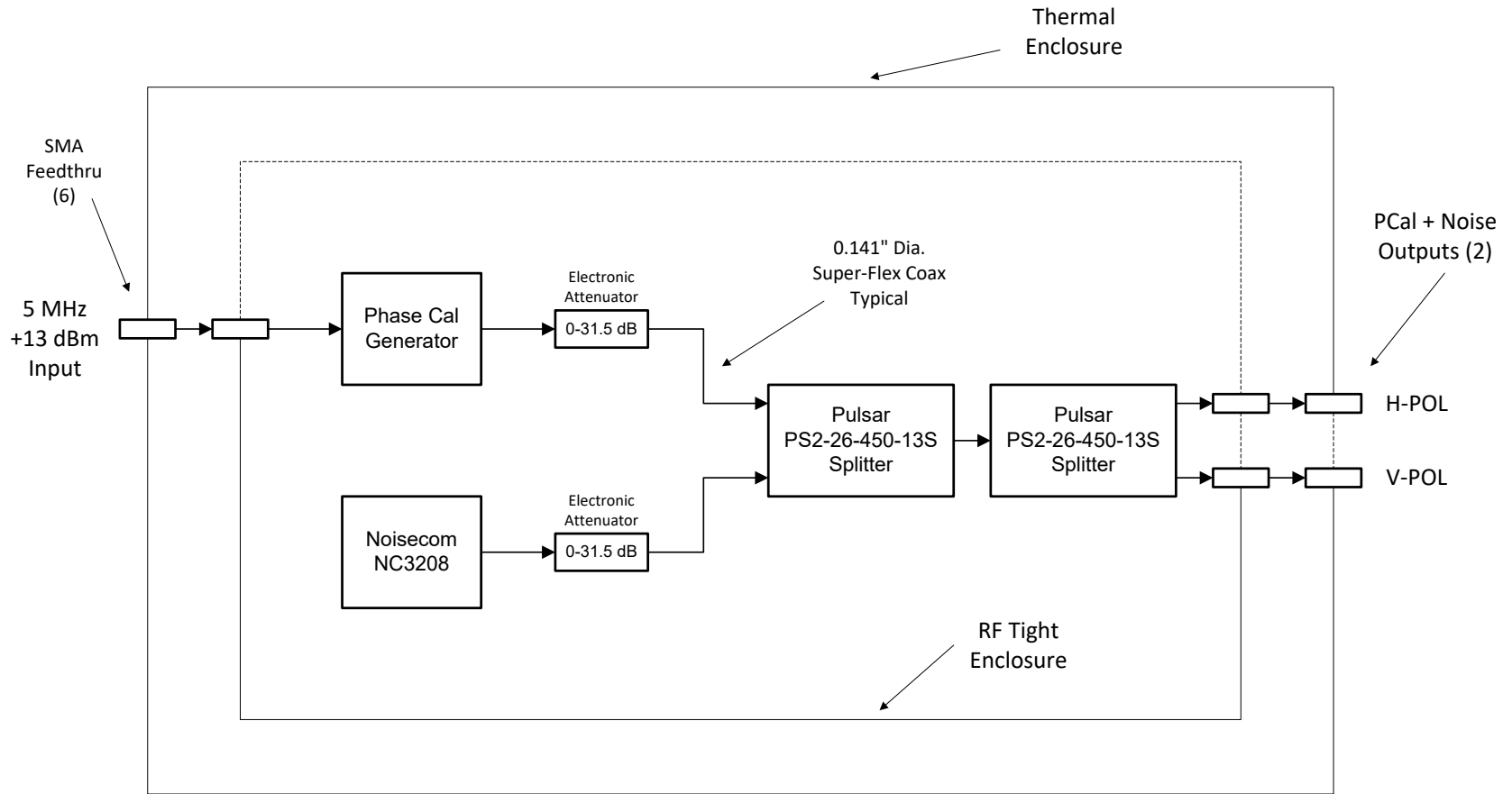

Broadband Phase/Noise Calibration Unit RF Wiring Diagram

Memos related to Phase Cal available online

- MIT Haystack Mark 5 development Memo series
(<https://www.haystack.mit.edu/tech/vlbi/mark5/memo.html>)
 - Mk5-020 Simulation of phase cal and low fringe rate phase error using a polyphase filter bank
 - Mk5-021 Phase Cal Extraction for the Mark 5B
 - Mk5-051 Measurements of cross-talk and spurious signals levels aer
 - Mk5-065 Proposed phase calibration scheme
 - Mk5-066 Measurements of cable delay with temperature and flexure
 - Mk5-071 Test of Hittite Logic gate
 - Mk5-074 Phase calibrator pulse distortion in UDC
 - Mk5-075 Preliminary circuit for the new phase cal
- MIT Haystack Broadband Memo series
(https://www.haystack.mit.edu/geo/vlbi_td/BB/memo.html)
 - BBDev-017 Modification to NASA/Honeywell pcal for 5 MHz repetition rate
 - BBDev-021 Phase cal performance during 2008 May 23 GGAO-Westford BBD test
 - BBDev-023 Tests of new "digital" phase calibrator
 - BBDev-031 Notes on phase cal extraction, power levels, total rail count, and SNR
 - BBDev-032 Phase Cal Channel-to-Channel Phase Discontinuities
 - BBDev-034 Phase Cal Amplitude RF Frequency Dependence

Spurious phase cal signals

- Definition: Spurious signal is a monochromatic signal
 - at the same RF, IF, or baseband frequency as a pcal tone
 - coherent over at least ~1 second with the pcal tone
 - but not the pcal signal that traversed the desired signal path.
- Spurs corrupt measured phase cal phase and amplitude.
 - For a -20 dBc spur, error in measured pcal signal is up to
 - 6° in phase \leftrightarrow 33 ps over 500 MHz
 - 10% in amplitude
- Examples of spurious signal sources:
 - Maser-locked signals generated in VLBI electronics (e.g., 5 MHz harmonics)
 - Phase cal images
 - Phase cal intermodulation/saturation
 - Secondary injection paths from pulse generator
 - Multipath from radiated phase cal
 - Cross-talk from other polarization
- Goal: Spurious signals >40 dB weaker than phase cal.
- For details, see pages 31-35 of

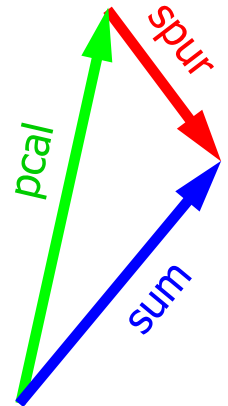

Diagnostic tests for spurious signals

- At a station -
 - Measure power level of a pcal tone on a spectrum analyzer.
 - Observe how far the level drops when steps are taken that **should** make pcal completely disappear. Examples:
 - Disconnect reference signal to pcal antenna unit.
 - Turn off pcal with ground unit switch (Mark4 cable cal systems).
 - Unlock receiver LO.
 - Offset receiver LO frequency from integer MHz.
 - Disconnect cable from antenna unit to cal injection coupler.
 - Level should drop >40 dB.
 - Analyzer resolution BW < 100 mHz may be needed to keep analyzer noise floor low enough to see a 40 dB drop.
- At a station or a correlator -
 - Plot pcal amplitude vs. pcal phase for pcal data extracted from recordings for many observations.
 - Look for quasi-sinusoidal pattern in amp vs. phase plot.

Origin of pcal amp vs. phase quasi-sinusoids

- Legend:
- True phase cal, rotated in steps of 90°
 - - -→ Spurious signal
 - Vector sum of true phase cal & spurious signal

- Case 1: Spurious signal of constant amplitude and phase
 - Amplitude of vector sum varies by one cycle as pcal phase varies 360° .

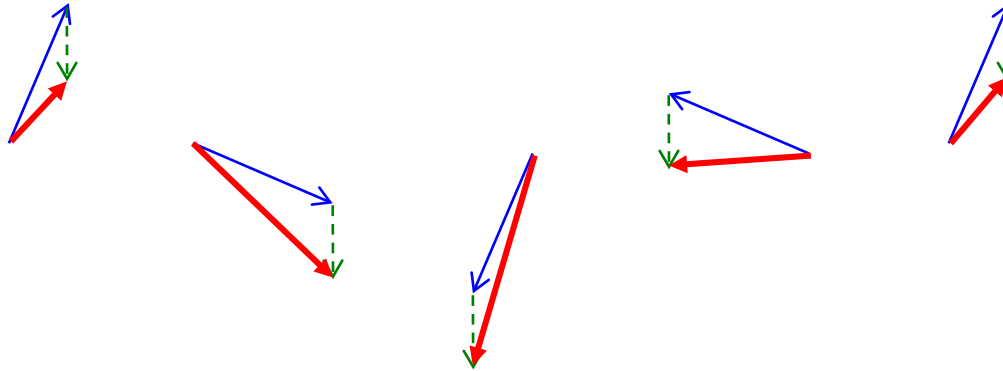

- Case 2: Spurious signal = phase cal at image frequency
 - Amplitude of vector sum varies by two cycles as pcal phase varies 360° .

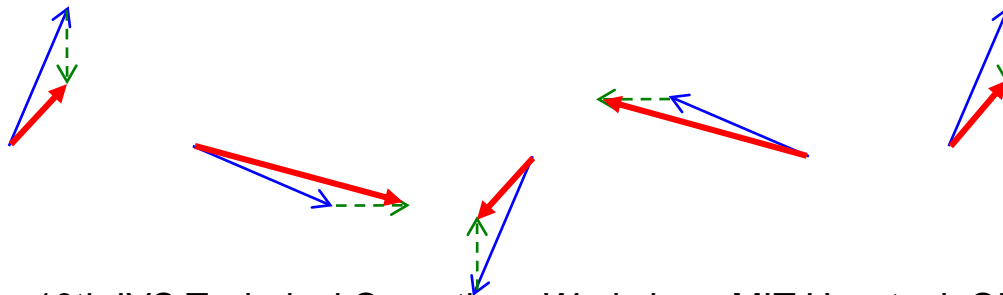

Spurious signal example: constant spur

Theory:

Pcal constant spur model for true pcal amp = 100 and spur amp = 10

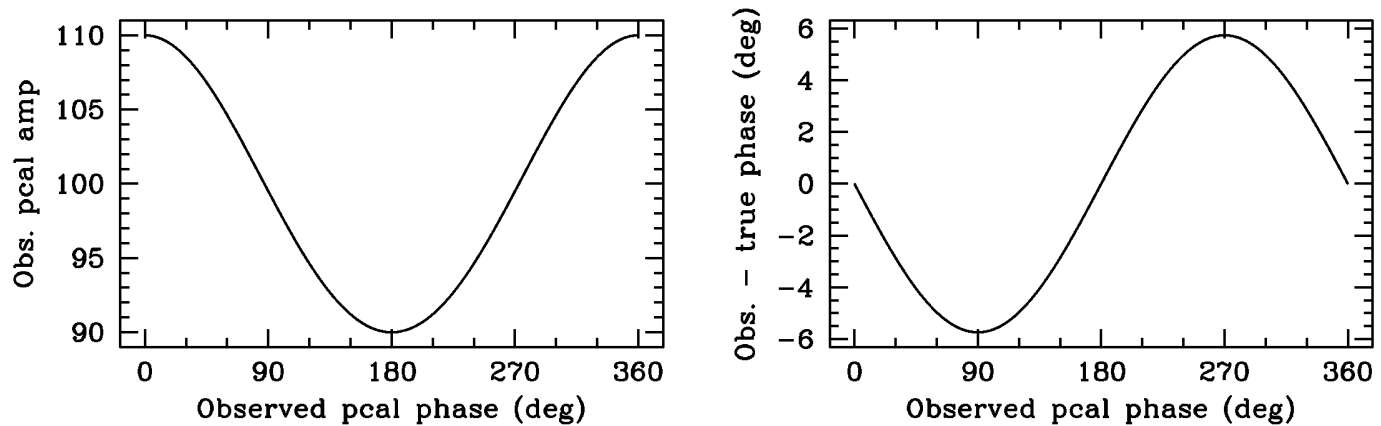

Observation:

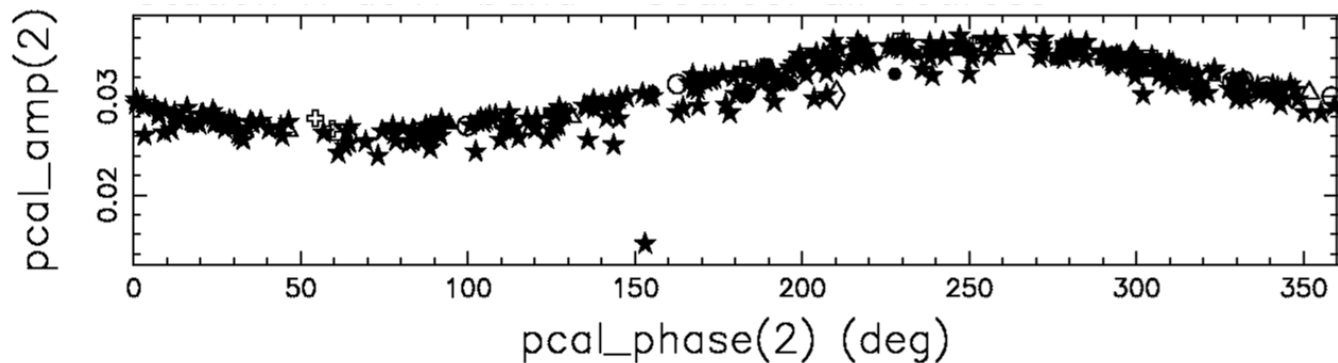

Spurious signal example: image spur

Theory:

Pcal image spur model with pcal amp = 100 and image amp = 50

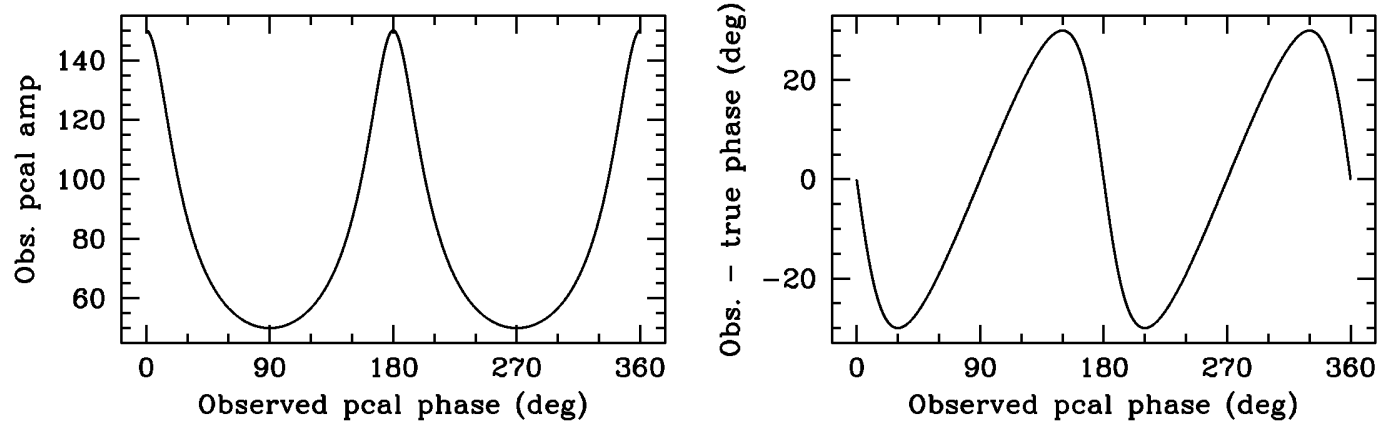

Observation:

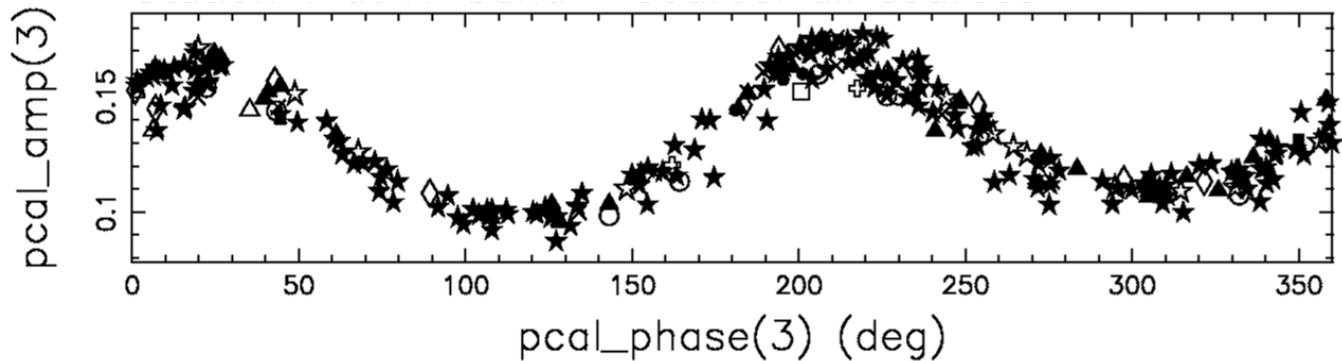

Why cable calibration?

- Where is the VLBI station?
 - On the antenna, at the intersection of axes,
 - **not** at the backend or maser.
- For **absolute** UT1 (= Earth rotation angle relative to Universe) measurements, absolute length of uplink and downlink must be measured.
 - We're not doing absolute (yet), so relax!
- For relative UT1 & other geodetic measurements, only variations in downlink (measured with phase cal) and uplink must be accounted for.
- Electrical length of uplink must be
 - stable or, if not,
 - measured for post-observation correction.

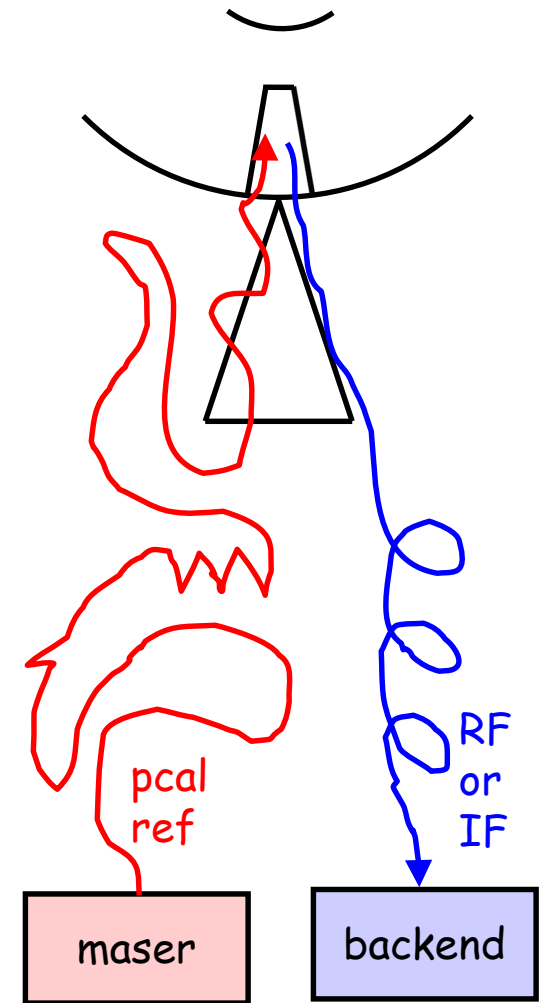

Cable calibration systems

- Measurement techniques include:
 - Use vector voltmeter in control room to measure phase difference between reference signals sent to receiver and returned from receiver.
 - If a single cable is used for transmitting both directions, reflections along the way can cause measurement errors.
 - If two cables are used, they may not behave in same manner.
 - Modulate reference signal in antenna unit before returning it to control room, to distinguish it from a reflected signal.
 - This is method used in Mark4 cable cal system.
- A cable measurement system is certainly needed for VGOS systems with a coaxial cable uplink.
 - VGOS limit on orientation-dependent uplink cable delay variations = <0.3 ps
 - Observed delay variations in RG-214 and LMR-400UF 5 MHz cables on GGAO and Westford antennas are $>\sim 1$ ps at best, and can increase over time.
- KPGO Signal Chain incorporates the new integrated calibrator module and cable delay is used in deriving the geodetic results.

Representative cable cal systems deployed

- Some system stabilize the transmitted phase rather than measure variations.
- Most optical fiber systems send the same frequency up and down separate fibers due to directional crosstalk in a single fiber.
 - Do lengths of up and down fibers change by the same amount?

<i>System</i>	<i>Cable no./type</i>	<i>Frequencies</i>	<i>Comments</i>
Mark 4	1 coax	5 MHz & 5 kHz	Does not meet VGOS spec.
VLBA	2 coax	500 MHz & 2 kHz	Modulates 500 MHz in frontend.
Koike Park	2 fibers	500 MHz	
NRAO 14-m	2 fibers	500 MHz	
JPL DSN	1 fiber	modulated 1 GHz	Phase stabilization
EVLA	2 fibers	512 MHz	
Arecibo	2 fibers	1.45 GHz	
KVG	1 coax or fiber	2 near 700 MHz	Phase stabilization or meas.
NASA VGOS	1 coax or fiber	5 MHz	In operation at Koike Park, soon at OSO

Cable Delay Measurement System (CDMS) Block Diagram

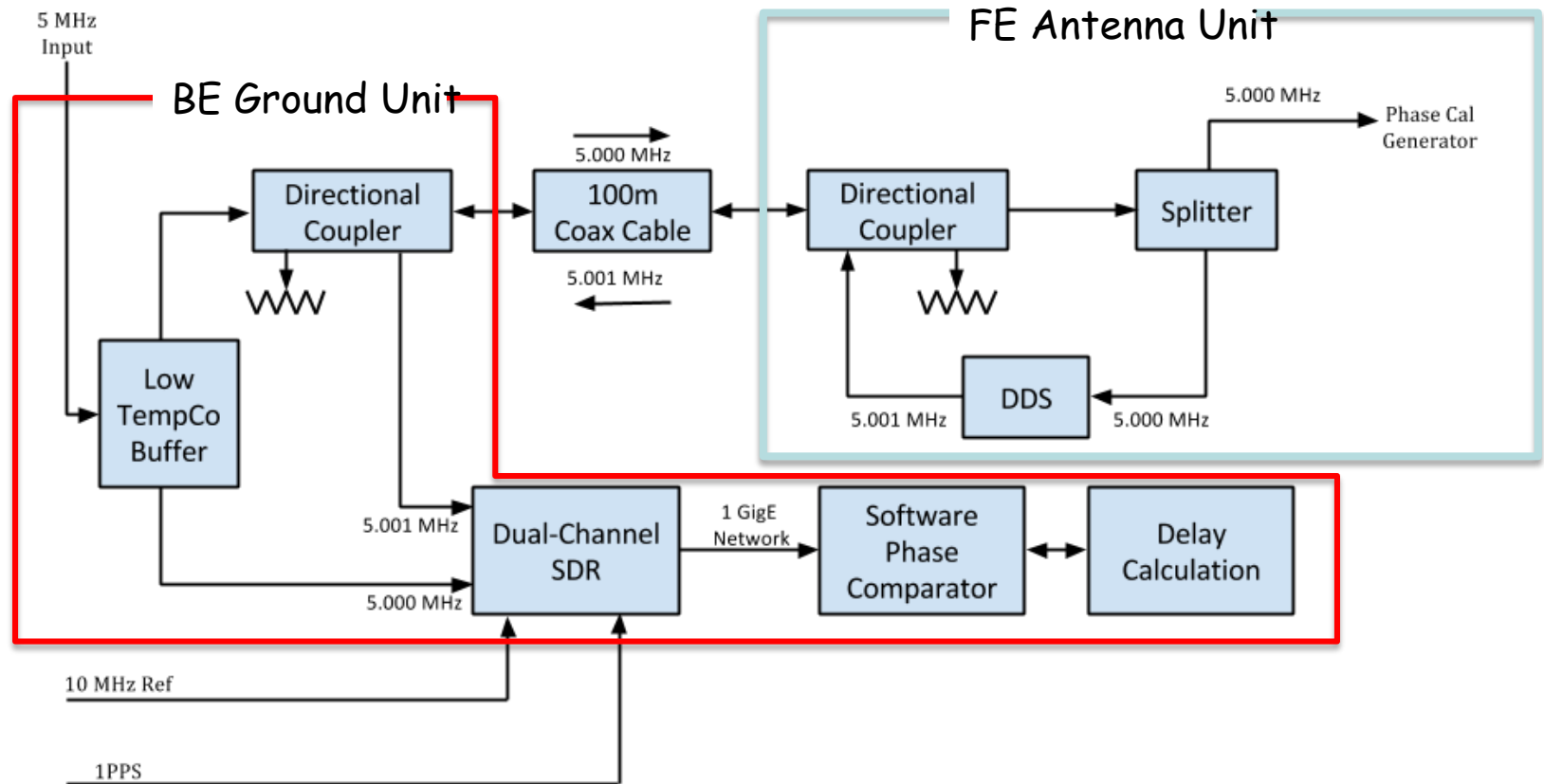

Calibration - Antenna Unit

Main Supply and drive signals

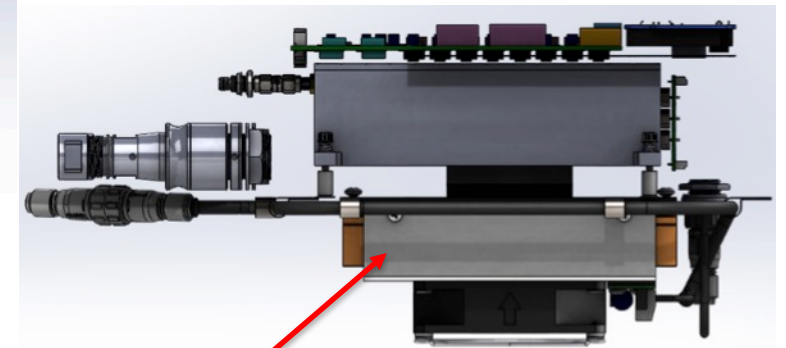
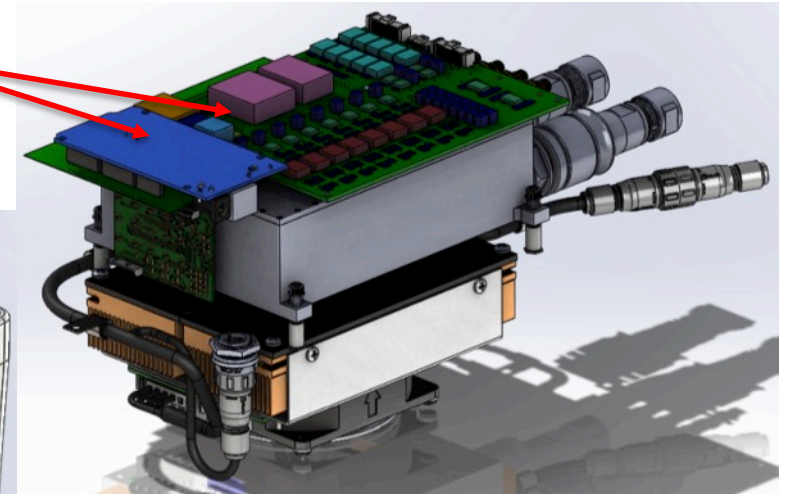
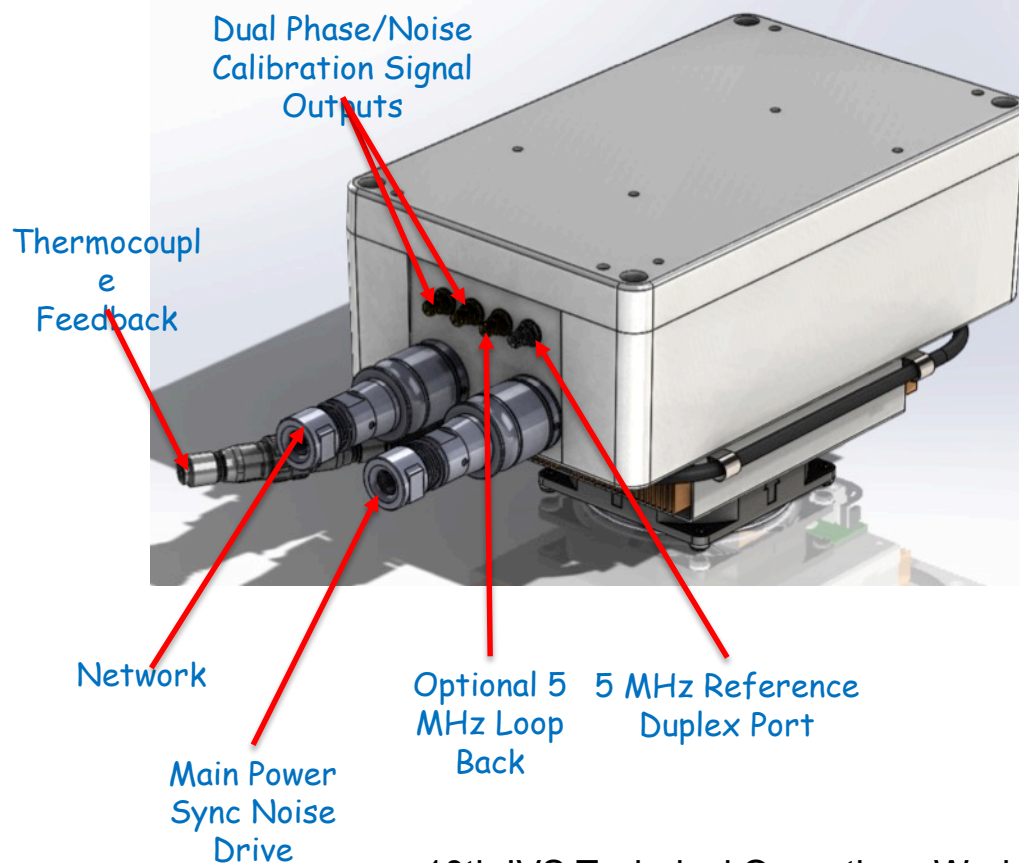

Calibration - Antenna Unit

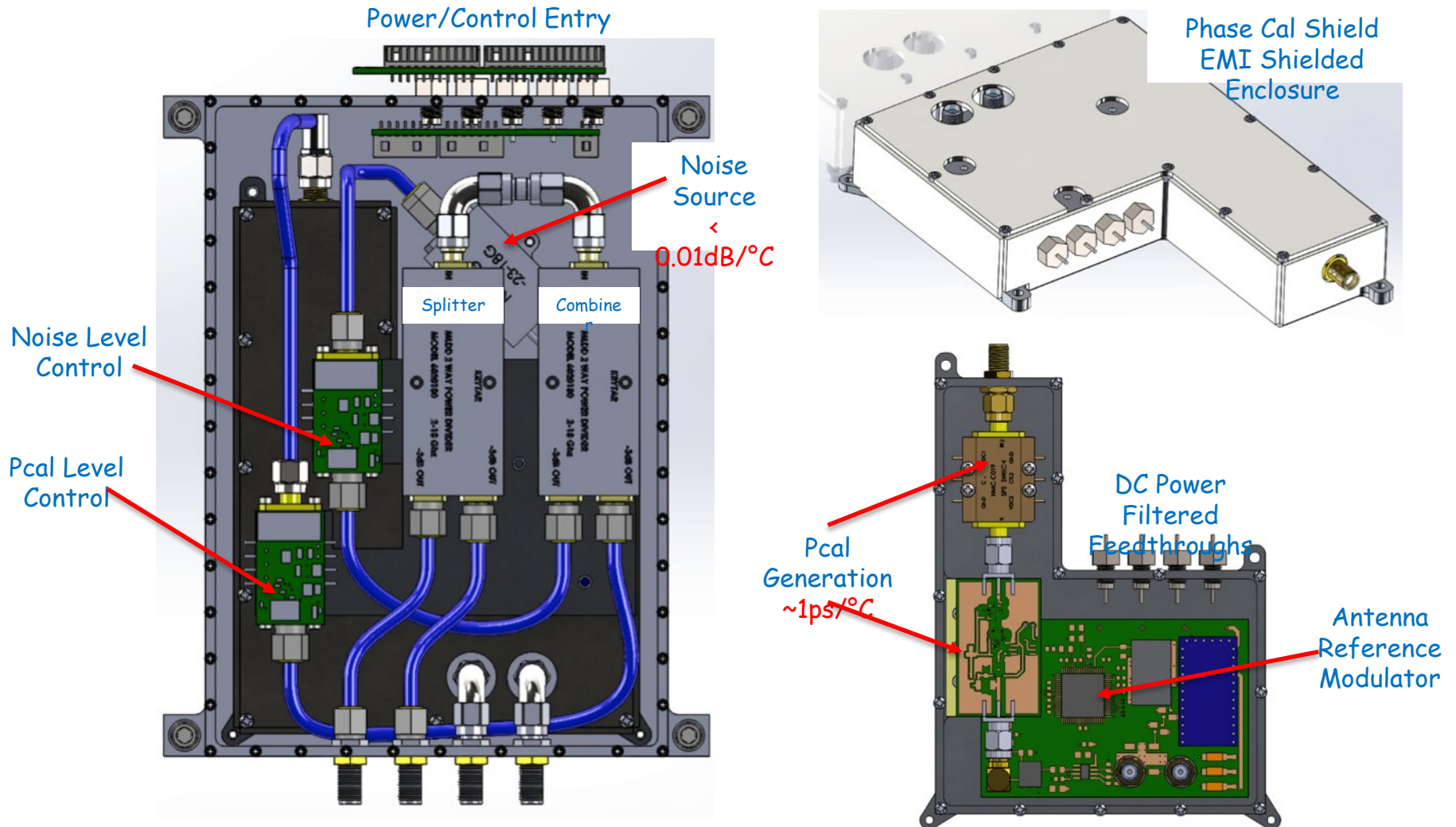

Calibration - Antenna Unit

Antenna Reference Modulator

Modulation
Synthesizer

Cable
Reference

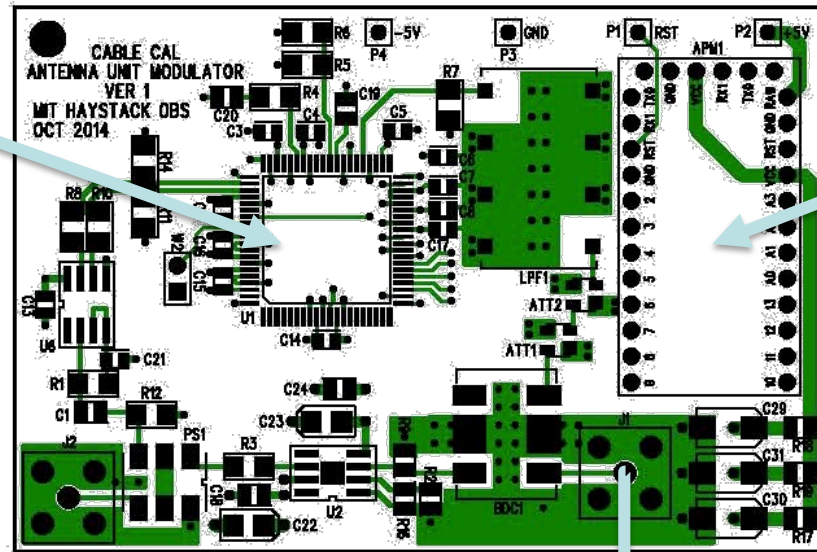

Programming
uCom

Pulse
Generator

Calibration - Ground Unit

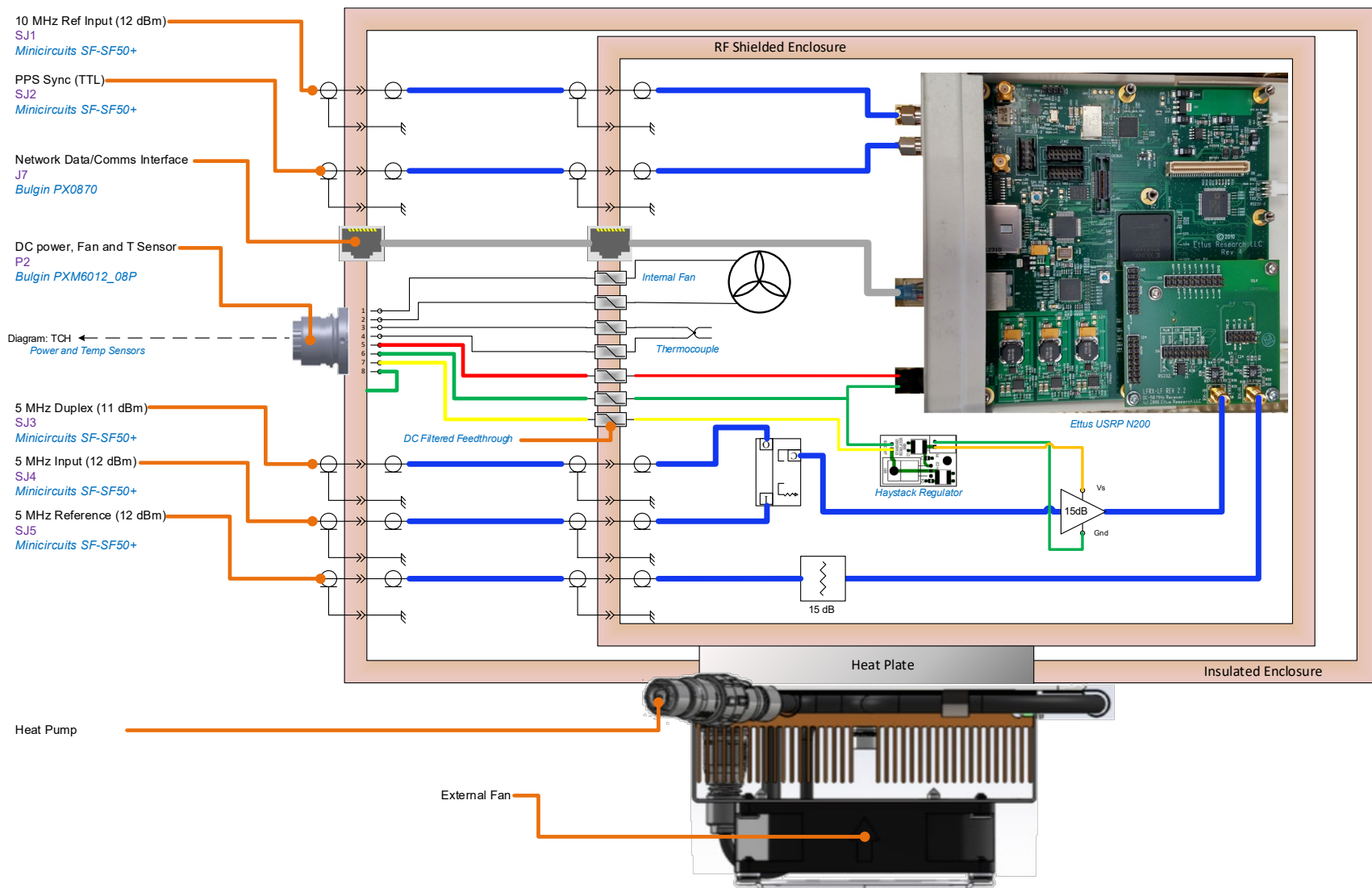

CDMS results at Westford & Kokee Park

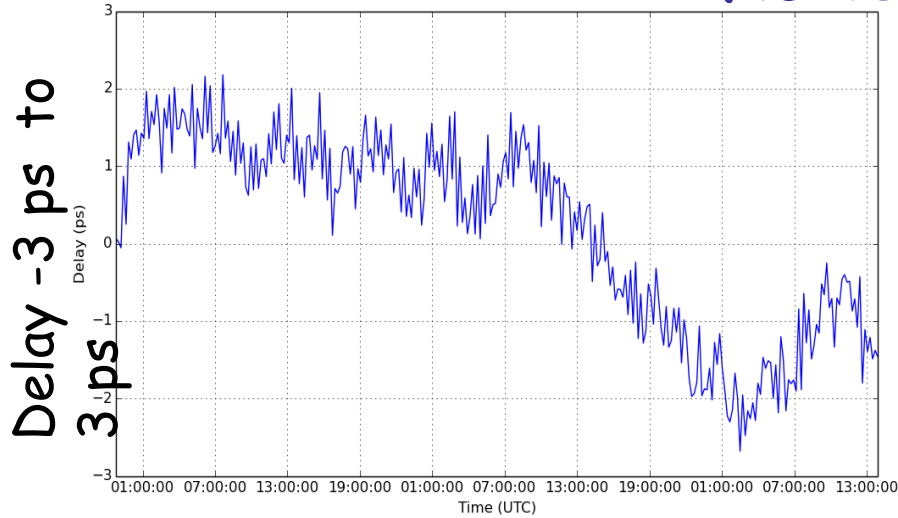

During 70 min
KBS session
K16043



Overnight testing at
Westford with ~1m
cable

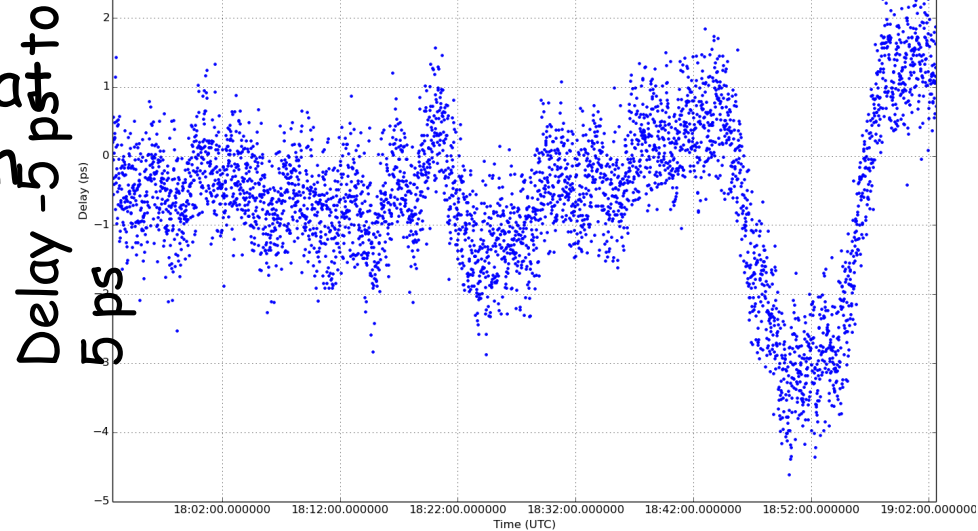

CDMS Results In-House Testing

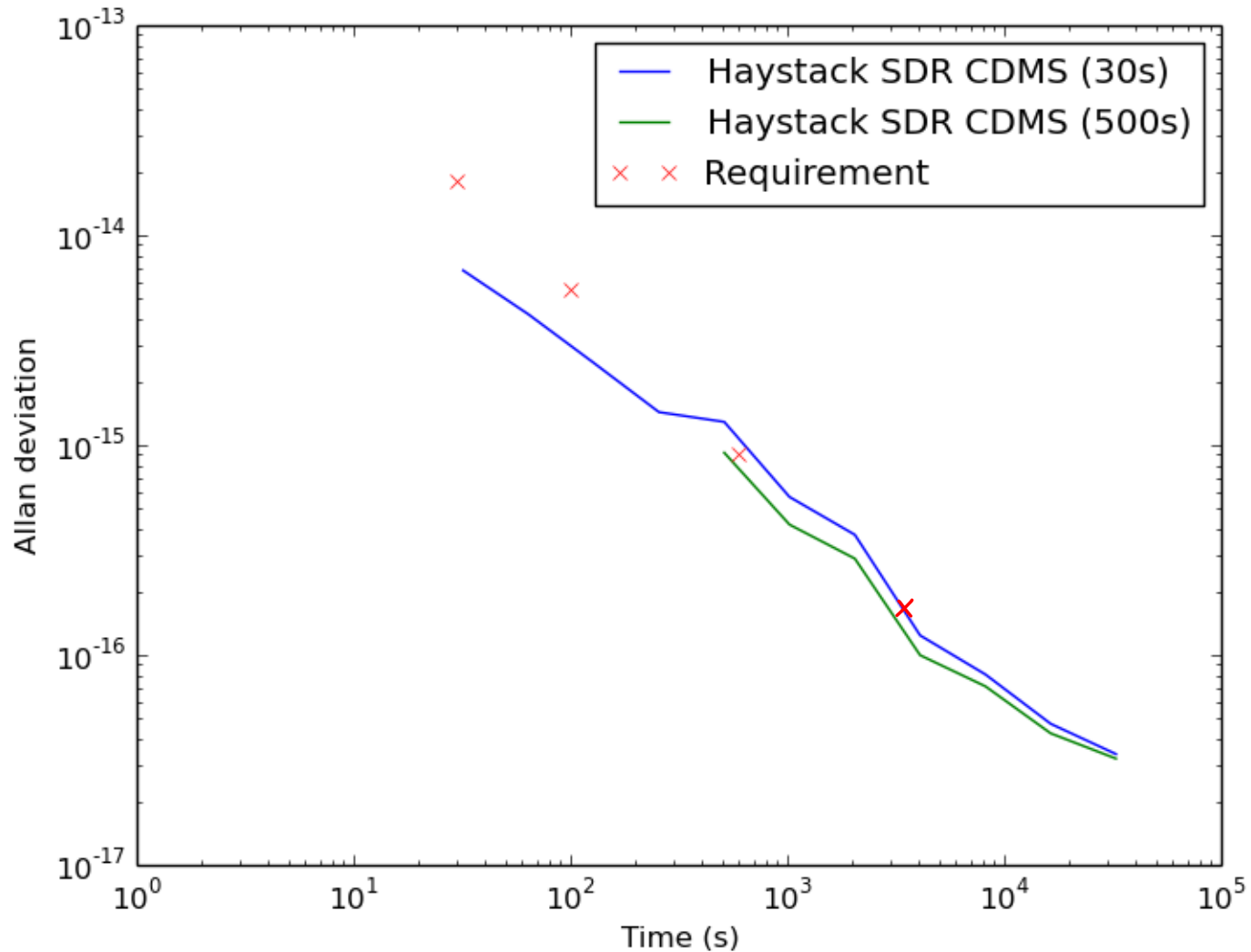

BACKUP SLIDES

Calibration - Delay Accuracy

Requirement: SCPB4.6.2

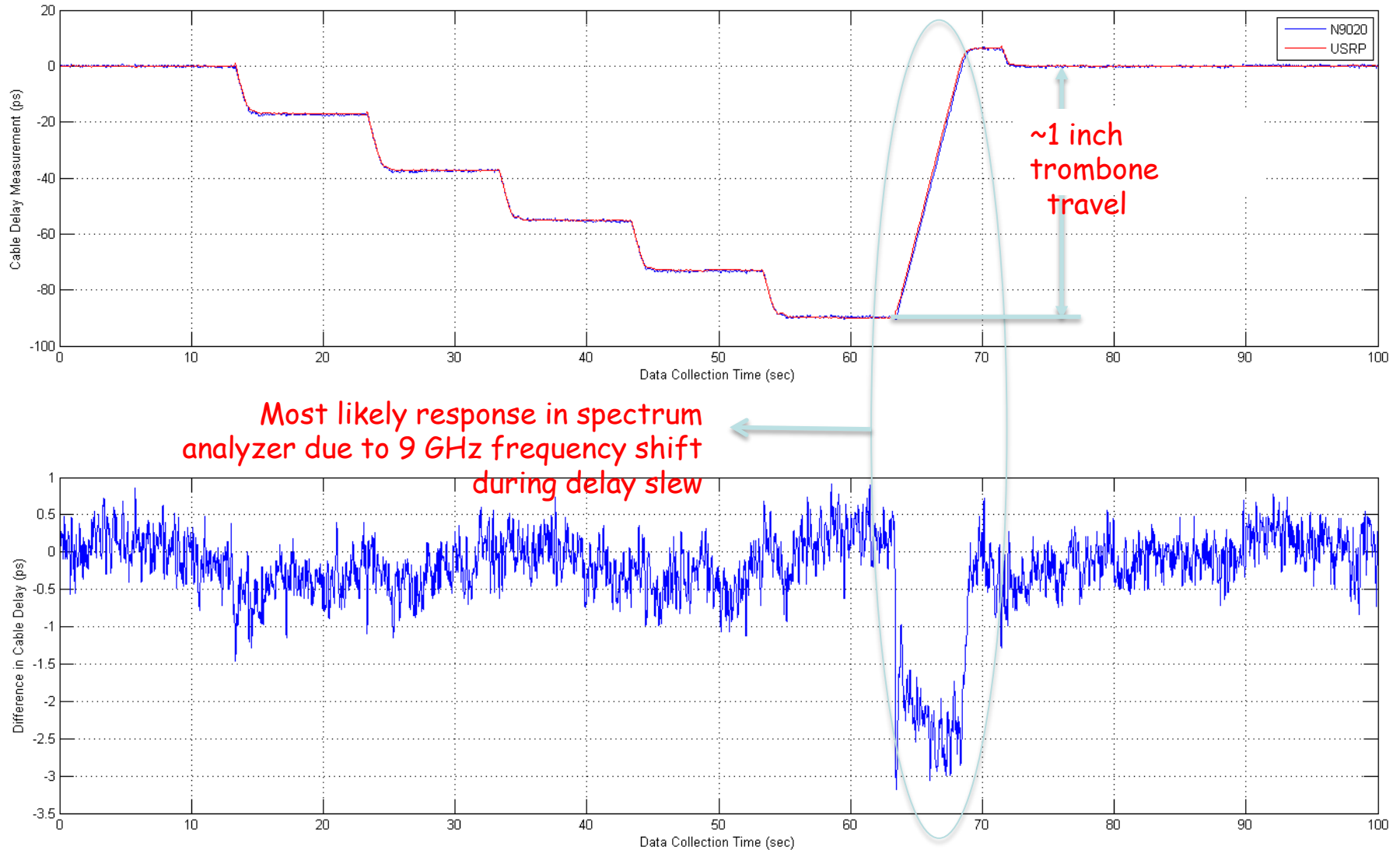

CDMS vs Mark-IV Comparison In-House

- Antenna at fixed position (start position)
- Moves between two sources
 - Required move to starting position before moving to new source
- On source for different durations
- Experimental Setup
 - Both units were operational at the same time
 - Different cables between ground and antenna units
 - Not exactly the same length
 - Accounts for the delay differences observed
- The temporal variation of delays track each other
 - Mark-IV cable delay shows a drift

CDMS Comparison at Westford

Wf Mark4 vs KPGO CDMS

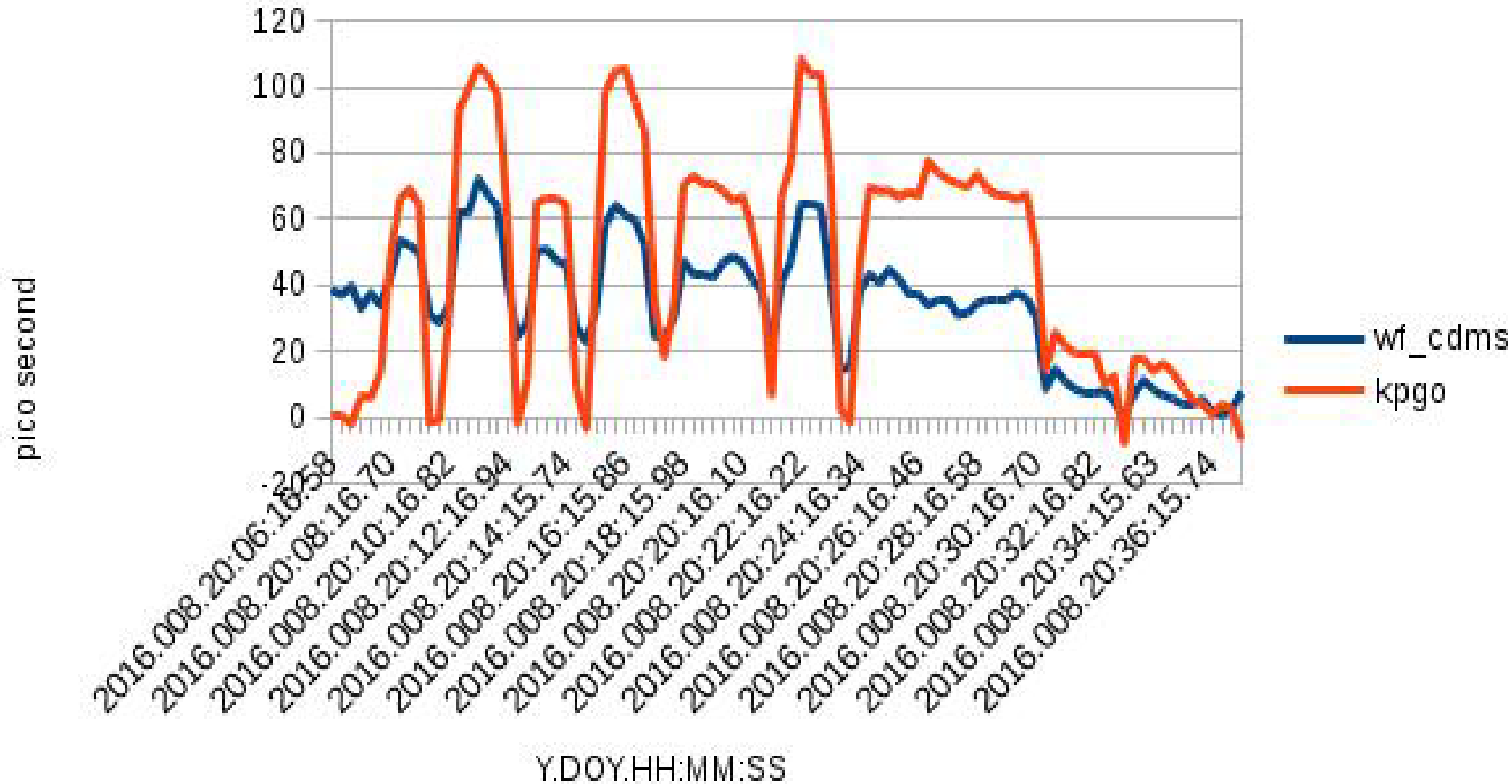

Basic parameters and functions of an analog spectrum analyzer

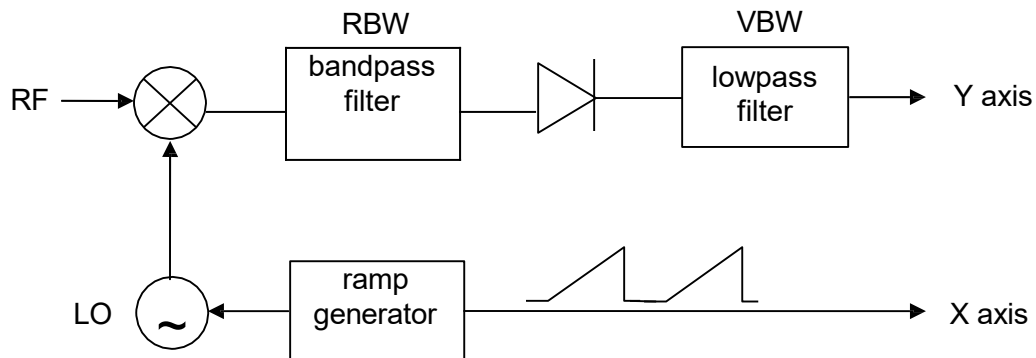

<i>Function</i>	<i>Description</i>
start/stop frequency	Displayed frequency range on x-axis.
center frequency/span	Ditto.
reference level	Power level at y-axis reference position, usually at top of display.
scale type	Logarithmic or linear scale on y-axis.
scale/div	Units per vertical division, usually 1, 2, 5, or 10 dB/div.
attenuation	Input attenuation. Decrease it to lower noise floor.
resolution bandwidth	Signal bandwidth of each instantaneous power measurement. Decrease it to improve sensitivity to narrowband signals.
video bandwidth	Cutoff frequency of lowpass filter following power detector. If video BW < resolution BW, output is smoothed, and sensitivity to impulsive signals is reduced.
video averaging	Display average spectrum from multiple sweeps.
sweep time	Time interval to draw trace once across screen. In order to maintain proper amplitude calibration, analyzer sets sweep time as a function of frequency span, resolution BW, and video BW.
max hold	Display max level measured at each frequency over repeated sweeps.
zero span	Configure analyzer as a fixed, tuned receiver to display power vs. time for the frequency range specified by center frequency and resolution BW.
marker	Use marker to measure frequency and power at selected points.

Resolution bandwidth

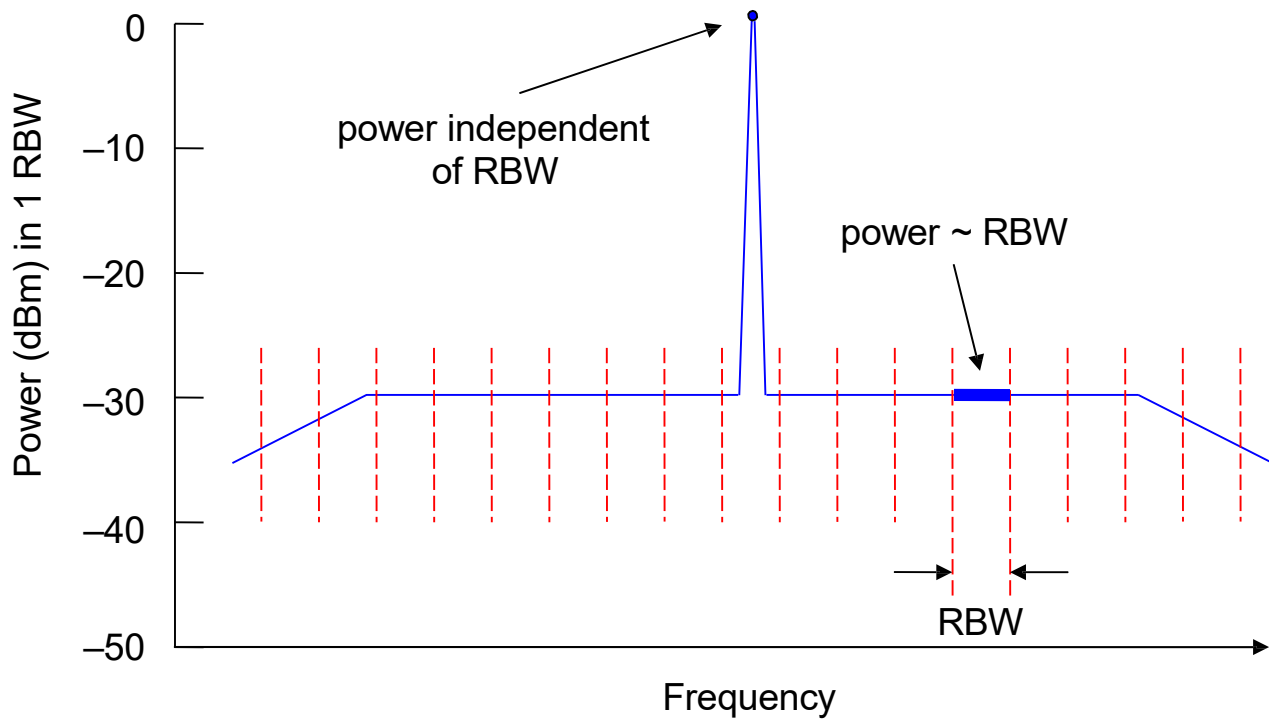

- For broadband noise with $BW > RBW$, power is proportional to RBW.
- For narrowband (e.g., CW) signals with $BW < RBW$, power is independent of RBW.

Detectors in spectrum analyzers with digital displays

Most modern spectrum analyzers use LCDs to display spectra, rather than the CRTs of older (purely analog) analyzers. With digital displays, the display resolution in both frequency and power is more limited.

The finite number of pixels in an LCD (as opposed to the effectively infinite number for a CRT) means that, for wide frequency spans and narrow RBWs, each pixel has to represent the spectral information for many sample points that lie within the frequency span of the pixel. It is left to the user to select which point to display in each pixel. Typical options include:

- *Max peak* (or simply *peak*) – the sample with the maximum power
- *Min peak* – the sample with the minimum power
- *Sample* – a “typical” value, usually either the first (in frequency) or central sample for each pixel
- *RMS* – power corresponding to the square of the RMS (root-mean-square) voltage magnitude of the samples for each pixel
- *Average* – power corresponding to the average mean voltage magnitude of the samples

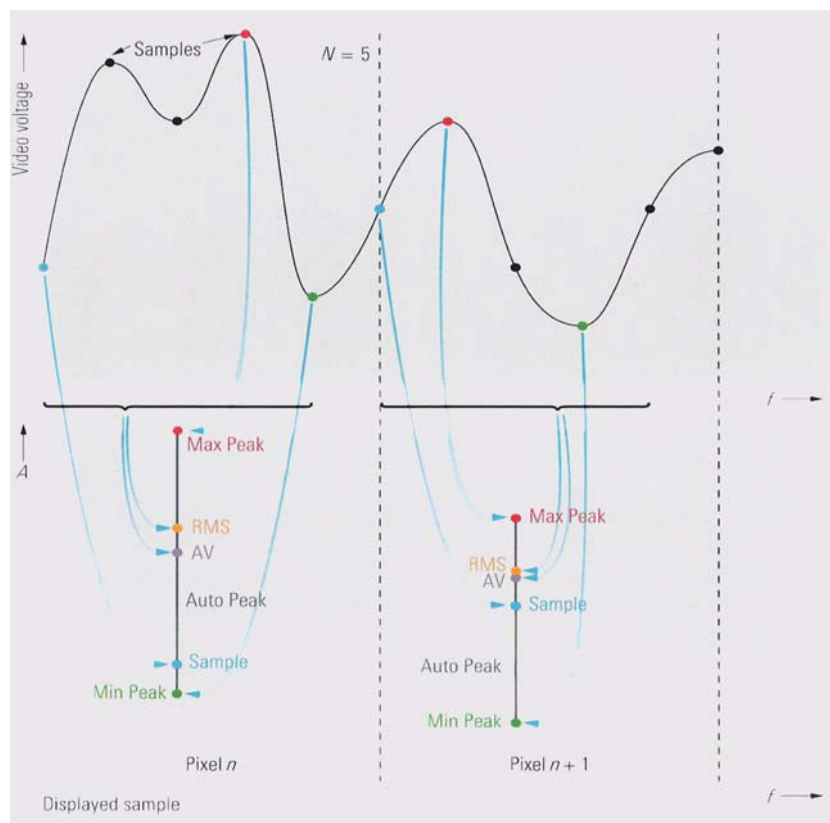

From *Fundamentals of Spectrum Analysis* by Christoph Rauscher, Rohde & Schwarz, 2007

Which detector type to use depends on the nature of the signal.

- In the presence of narrowband signals, *max peak* ensures that no signal is missed.
- When only broadband, noise-like signals are present, *sample*, *RMS*, or *average* detection better represents the spectrum than does *max peak*, which will show the upper envelope of the spread in power.

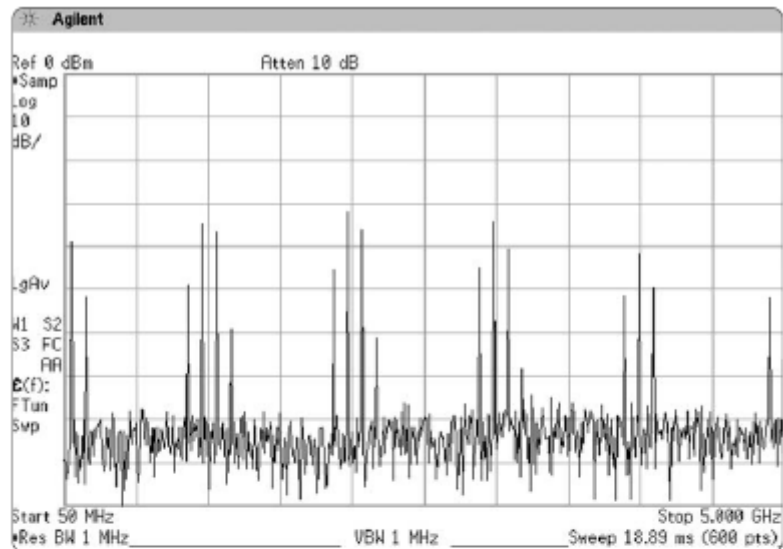

Figure 2-22a. A 5 GHz span of a 100 MHz comb in the sample display mode

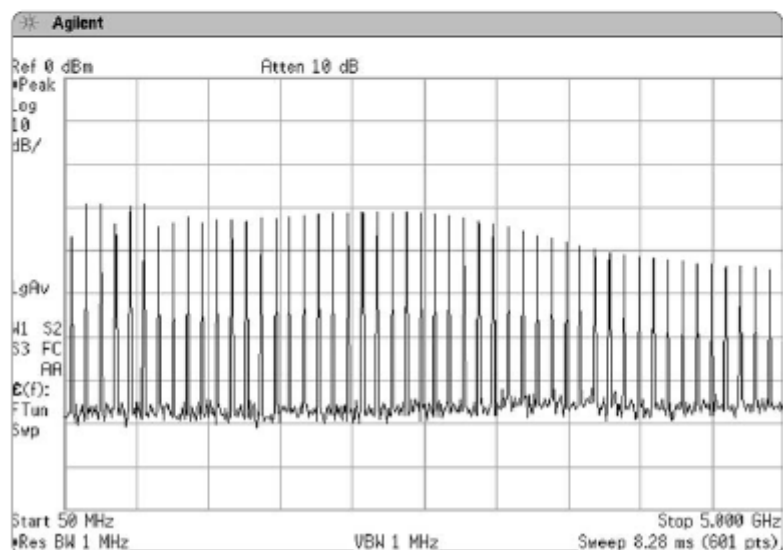
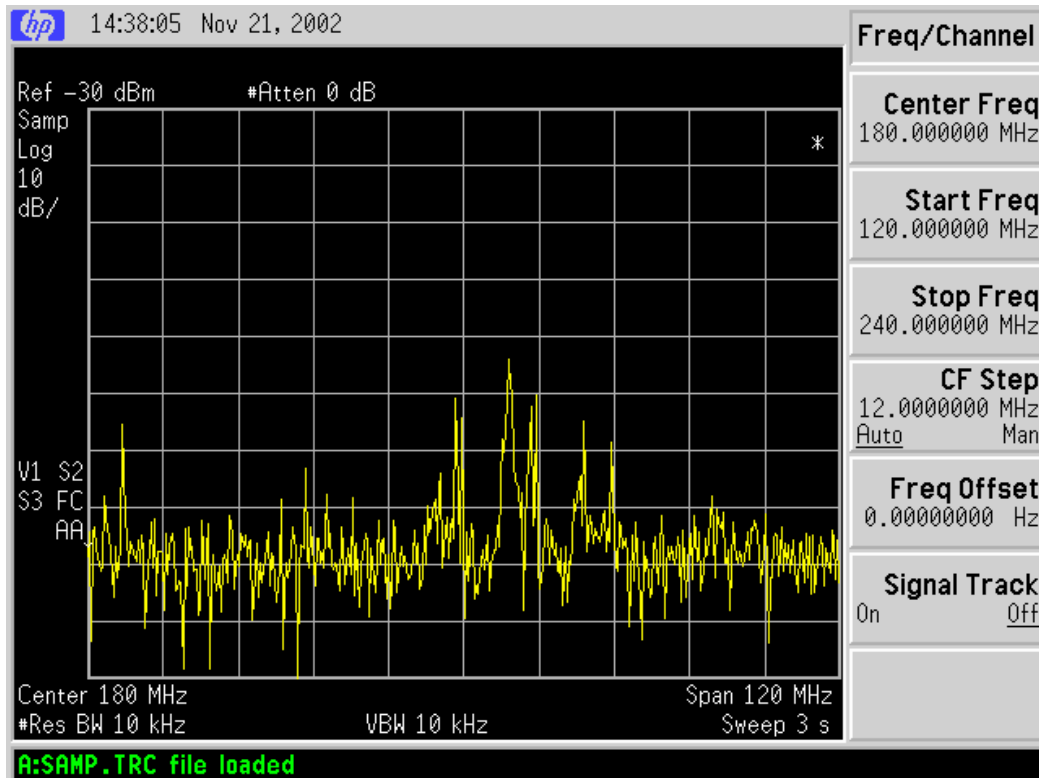
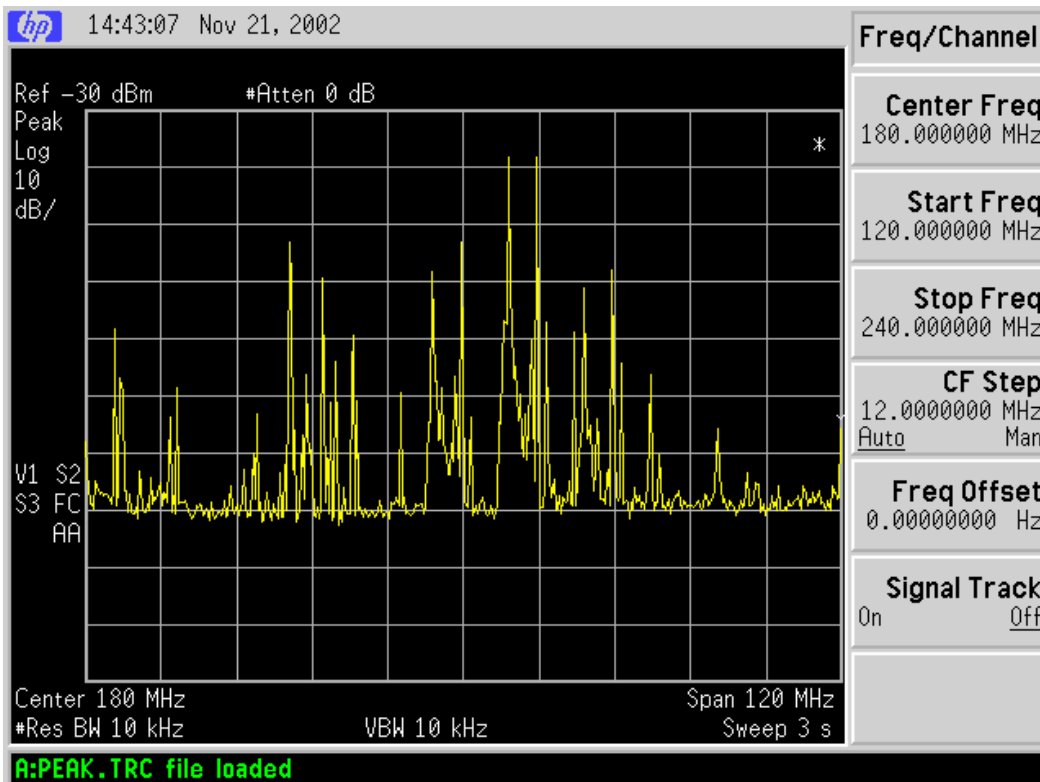

Figure 2-22b. The actual comb over a 500 MHz span using peak (positive) detection

From Agilent Application Note 150: Spectrum Analysis Basics

RFI-rich spectrum using peak (top) & sample (bottom) detection



Some spectrum analyzer applications in VLBI

- Measure frequency response of active and passive components, e.g., filters and amplifiers.
- Measure cable loss, e.g., in cables to antenna.
- Look for ripple in broadband RF or IF signals as evidence of impedance mismatches.
- Measure LO phase noise and estimate LO phase jitter. (See "Notes on Phase Modulation of LO Signals" and IF3 LO phase noise example.)
- Test for presence of phase cal or LO modulation by measuring the carrier-to-noise power ratio of a phase cal tone and comparing against broadband power measurements. (See notes on "Using a spectrum analyzer to test for LO or phase cal modulation.")
- Search for sideband modulation on a CW-type signal. For example:
 - 50 or 60 Hz sidebands on an LO, phase cal tone, or reference frequency signal (e.g., 5 or 500 MHz).
 - 5 kHz sidebands on phase cal tones due to MkIV cable measurement system.
 - CW sidebands on LO signal originating in phase-locked loop (e.g., 10 kHz sidebands on LO in VLBA BBC or MkIV VC).
- Search for spurious phase cal signals by turning off phase cal or unlocking the receiver LO and then looking for signals at normal phase cal frequencies.
- Search for RFI in IF or baseband signals.
- Use zero-span mode to examine temporal variability in a narrow frequency range.
- Use the analyzer as a power meter, to measure the total power over a specified frequency range, or as a frequency counter, to measure the frequency of narrowband signals.

Impedance Mismatches and Reflections

- Coax or waveguide transmission lines have constant characteristic impedance $Z_c = V/I$. ($Z_c = 50 \Omega$ is common for coax.)
- If line is terminated with active or passive device having impedance Z_c , all incident power will be absorbed without reflection.
- If device has impedance $\neq Z_c$, or if line has a break or bad connector, some power will be reflected.
 \Rightarrow Gain is decreased, and amplifier driving line may oscillate.
- If multiple abrupt impedance changes are present, multiple reflections cause ripple in power and phase spectra.

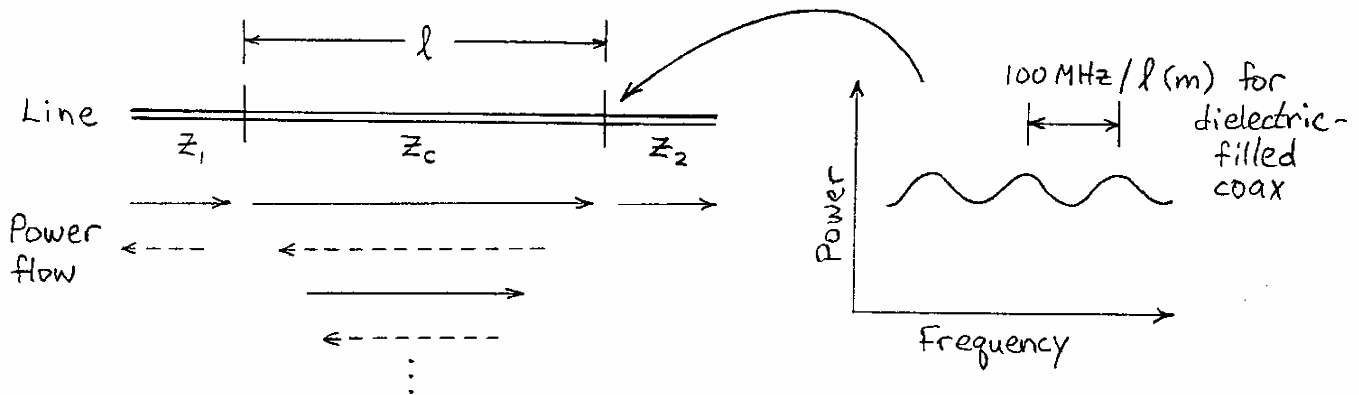

Example:
 Ripple in IF power spectrum
 due to multiple reflections over
 0.7-meter and 5-meter cable
 lengths.

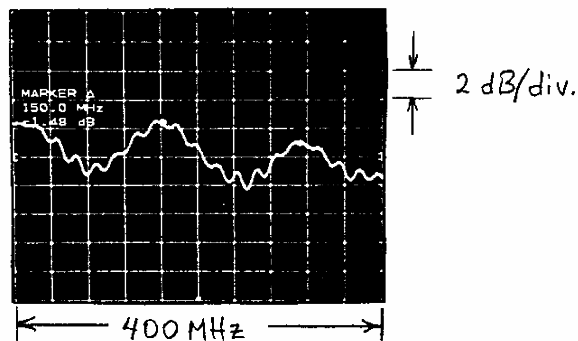

- Multiple reflections are particularly serious if they occur before the phase cal injection point, either between feed and coupler or between phase cal antenna unit and coupler.
- Even more serious are unstable, time-dependent changes in phase ripple caused by multiple reflections, which can affect measured group delay.

Phase Modulation of LO Signals

$$V_{LO}(t) = \cos[\omega_{LO}t + \phi + mod(t)]$$

Example of phase modulation in time domain:

- Unmodulated pure sine wave [$mod(t) = 0$]
- - - - Modulated sine wave with $mod(t) = (\pi/2 \text{ radians}) \times \sin \omega_{LO}t/3$

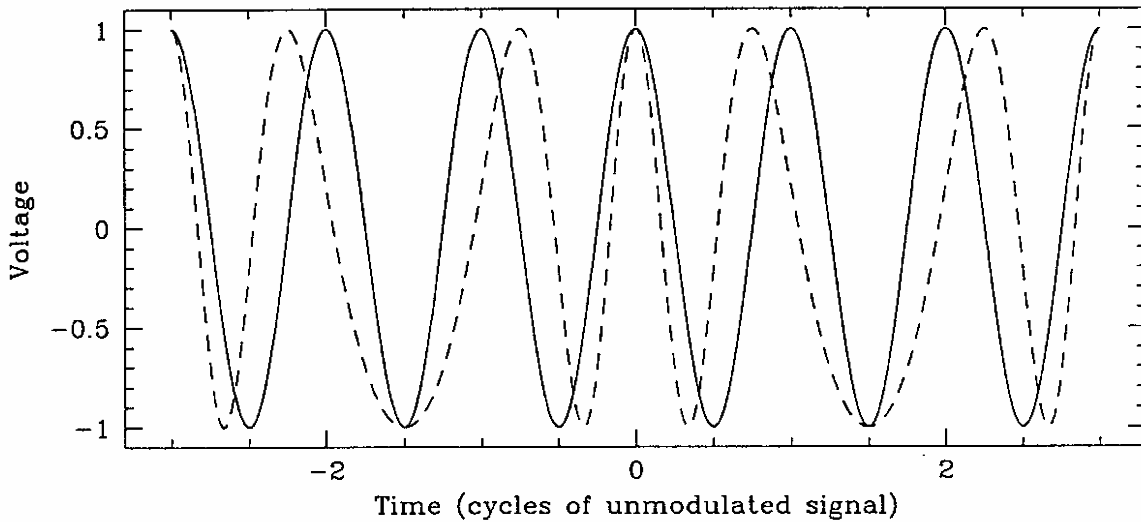

For $mod(t) = \alpha \sin \omega_m t$ and $\alpha \ll 1$ radian,

$$V_{LO}(t) \approx \cos(\omega_{LO}t + \phi) + \frac{\alpha}{2} \left[\underbrace{\cos(\omega_{LO} + \omega_m)t}_{\text{USB}} - \underbrace{\cos(\omega_{LO} - \omega_m)t}_{\text{LSB}} \right]$$

In general case, for arbitrary $mod(t)$,

- spectrum of modulated signal has upper and lower sidebands on either side of LO frequency, and
- amplitude of $\cos \omega_{LO}t$ term is reduced compared to unmodulated case.

LO Phase Modulation in Geodetic VLBI

- Modulation of LO in receiver or in VC/BBC causes
 - loss of phase coherence in baseband signals relative to signals at other VLBI stations
 - degradation of VLBI sensitivity
 - shifting of signal power to modulation sidebands.
- Low-level modulation of a low-frequency LO reference signal can lead to strong modulation at high LO frequencies:

When frequency f_1 is multiplied up to f_2 , phase noise (in degrees or radians) is multiplied by ratio f_2/f_1 , and strength of modulation side bands is increased by $20 \log_{10}(f_2/f_1)$ dB.

 - Example: Modulation sidebands on a 5 MHz LO reference will be $20 \log_{10}(8080/5) = 64$ dB stronger at $f_{LO} = 8080$ MHz.
- A common source of modulation is 50/60 Hz hum in power supplies.
 - Example: Power spectrum of 1700 MHz LO locked to 5 MHz reference signal with weak 60 Hz modulation -

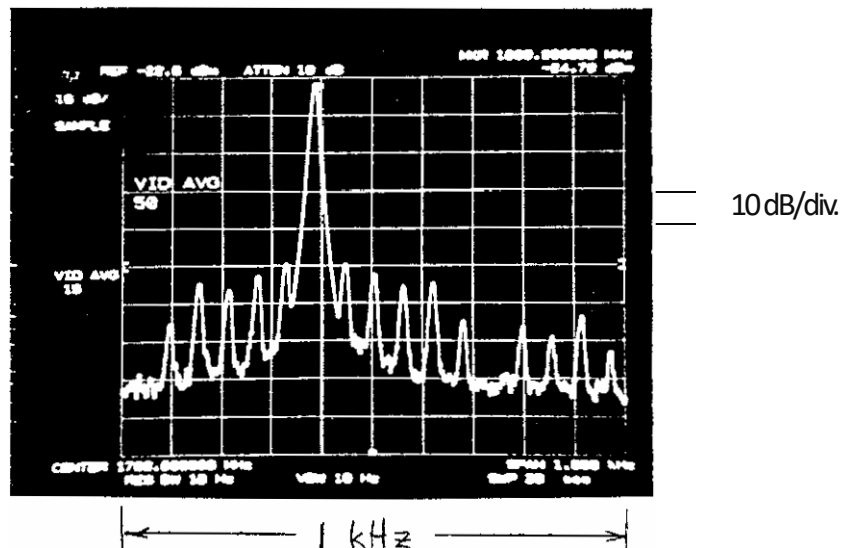

- LO modulation sidebands in VLBI systems should be > 30 dB below the LO carrier.

Measuring carrier phase noise

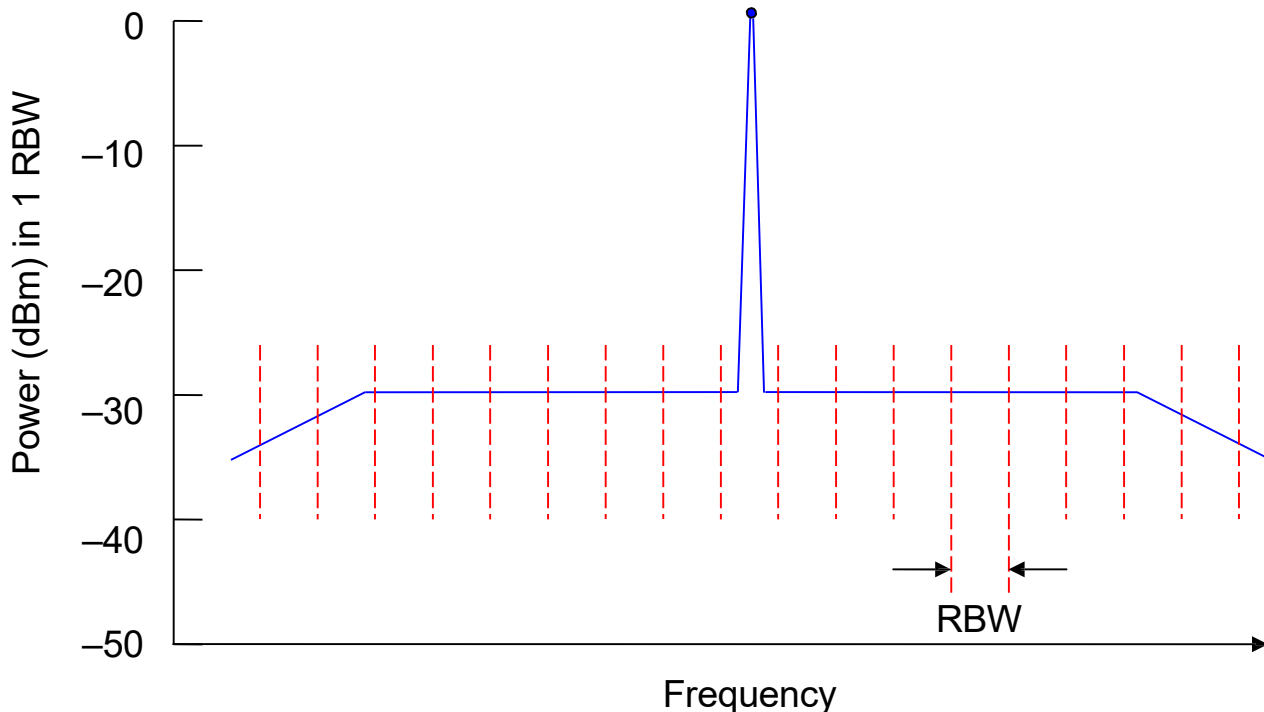

- Phase noise of a carrier = total power in two modulation sidebands
- RMS phase jitter of a carrier in radians = $\sqrt{(\text{power in 2 sidebands}) / (\text{power in carrier})}$

Example: Calculate carrier phase noise for spectrum above, out to the “knees” in the spectrum

Phase noise level is -30 dBm/RBW out to 6 RBWs away from carrier.
 \rightarrow power in 2 sidebands = $2 \times (0.001 \text{ mW} / \text{RBW}) \times (6 \text{ RBW})$
 $= 0.012 \text{ mW}$

In practice, power is usually calculated from frequency span & RBW.
 For example, if span = 12 kHz and RBW = 1 kHz,
 power in 2 sidebands = $(0.001 \text{ mW} / 1 \text{ kHz}) \times (12 \text{ kHz}) = 0.012 \text{ mW}$

Power in carrier = 0 dBm = 1 mW

RMS phase jitter of carrier = $\sqrt{0.012 \text{ mW} / 1 \text{ mW}}$ radian
 $= 0.11 \text{ radian} = 6 \text{ degrees}$

Phase-locked oscillators

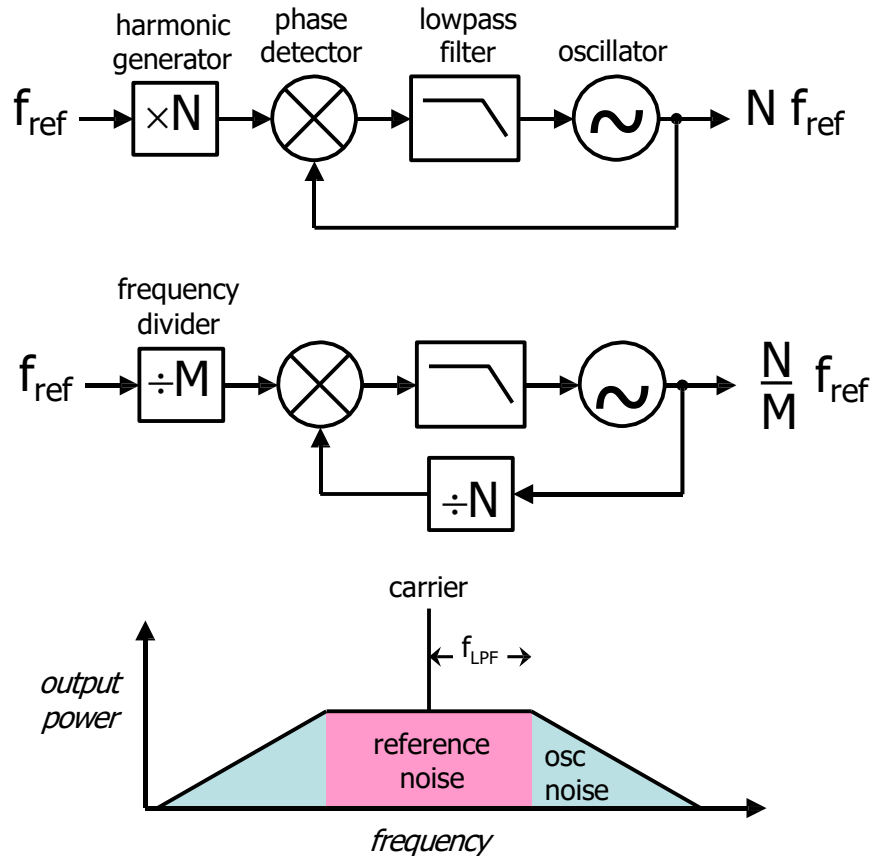

- PLOs use a reference frequency to steer an oscillator on long time scales ($> \mu\text{s}$ to ms).
- PLO phase noise outside the loop BW (= lowpass cutoff frequency) is generally lower than that of reference signal multiplied up to output frequency.
- First circuit above is common in receiver LOs.
- VC/BBC PLO uses second circuit with $f_{\text{ref}} = 5 \text{ MHz}$ and $M = 500$.
→ Output can be varied in steps of 10 kHz .

Indirect detection of severe phase cal modulation

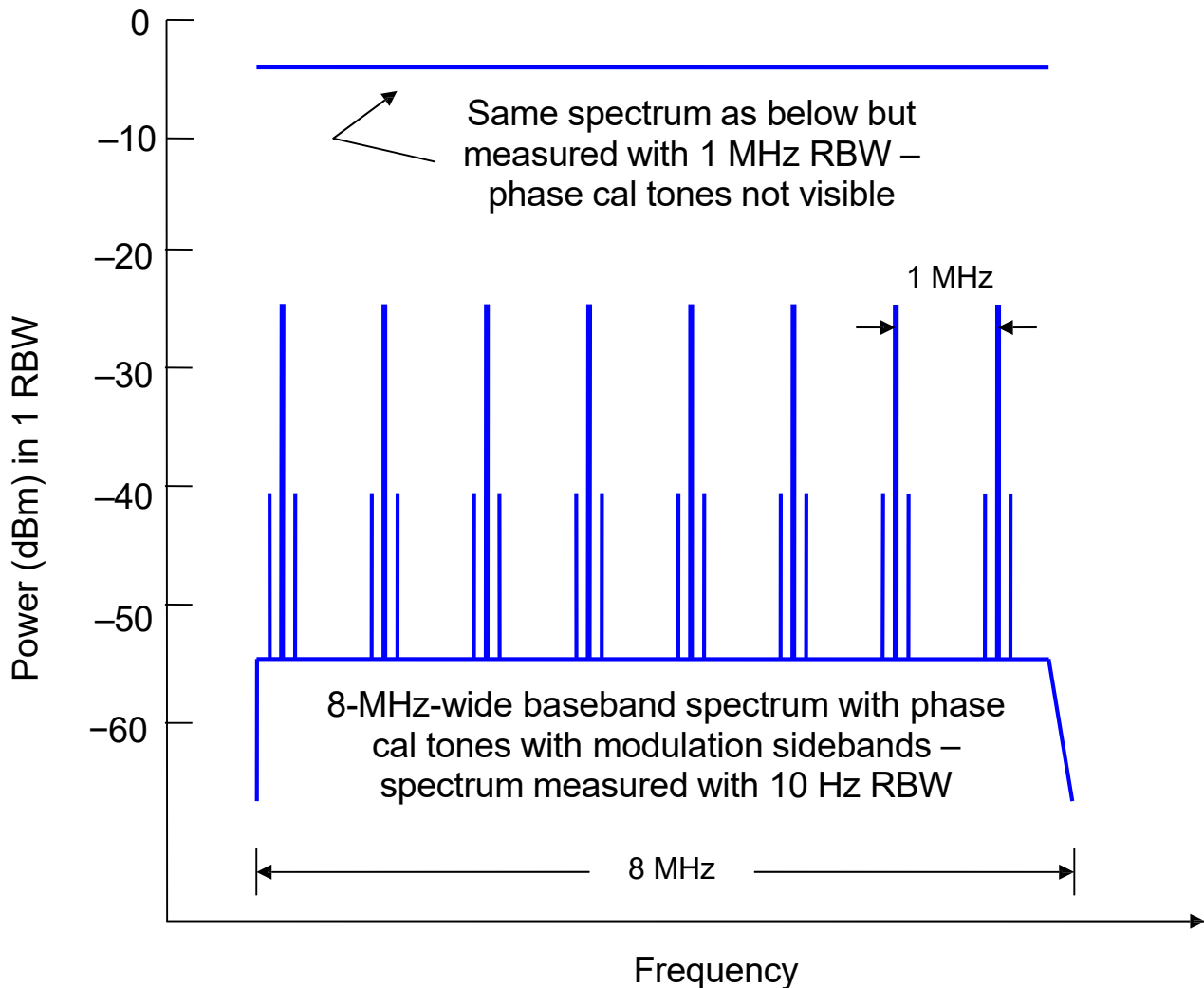

Measure the strength of phase cal relative to system noise in two ways:

1. Measure height of phase cal tone relative to broadband system noise with a narrow RBW. Typically phase cal is about 30 dB above noise with a 10-Hz RBW. From this measurement, calculate ratio of phase cal tone power to system power over a 1-MHz bandwidth. Value should be approximately -20 dB, i.e., phase cal is ~1% of total system power.
2. Using total power detector, measure change in baseband power level as phase cal is turned on and off.

Compare the estimates of the pcal/system power ratio from the 2 methods. If the first ratio is smaller than the second ratio by >1 dB, phase cal power is probably being lost to modulation sidebands, which might not otherwise be easily observed due to their unknown frequency range and structure.

Analyzers for phase cal spurious signal detection

- Detecting phase cal spurious signals at -50 dBc requires, for typical phase cal power levels, an analyzer resolution BW of order 10 mHz.
- Typical big-box analog analyzers have a minimum RBW of 1-10 Hz.
- Analyzers with narrower RBW suitable for spurious signal detection include:
 - Low-frequency (up to ~1 MHz) FFT analyzer such as antique HP 3582A and HP 35660A.
 - Software-defined radios (SDRs)
 - SDRs are an economical alternative to bench-top of analysers.